



Nikon

Inverted Microscope

ECLIPSE

Ti-E* *Ti-E/B

Instructions

Introduction

Thank you for purchasing a Nikon product.

This instruction manual is written for users of Nikon Inverted Microscope Eclipse Ti-E and Ti-E/B.

To ensure correct usage, read this manual carefully before operating the product.

- No part of this manual may be reproduced or transmitted in any form without prior written permission from Nikon.
- The contents of this manual are subject to change without notice.
- Although every effort has been made to ensure the accuracy of this manual, errors or inconsistencies may remain. If you note any points that are unclear or incorrect, please contact your nearest Nikon representative.
- Some of the equipment described in this manual may not be included in the set you have purchased.
- If you intend to use any other equipment with this product, read the manual for that equipment too.
- When using TI-HUBC/A Hub Controller A with the microscope, also refer to the instructions manual provided with the hub controller.
- If the equipment is used in a manner not specified by the manufacturer, the protection provided by the equipment may be impaired.



Safety Precautions

To ensure correct and safe operation, read this manual before using the product.

Warning and Caution Symbols in this Manual




Although this product is designed to be completely safe during use, incorrect usage or failure to follow the safety instructions provided may cause personal injury or property damage. To ensure correct usage, read this manual carefully before using the product. Do not discard this manual and keep it handy for easy reference.

Safety instructions in this manual are marked with the following symbols to highlight their importance. For your safety, always follow the instructions marked with these symbols.

Symbol	Description
 Warning	Disregarding instructions marked with this symbol may lead to serious injury or death.
 Caution	Disregarding instructions marked with this symbol may lead to injury or property damage.

Symbols on the Product

The symbols on the product indicate the need for caution at all times during use. Before operating a part labeled with the following symbols, refer to the instruction manual and read the relevant instructions.

Symbol	Meaning
	<p>CAUTION: HOT</p> <p>This symbol can be found on the top of the dia pillar illuminator and on the 12V 100W lamphouse, and cautions the following:</p> <ul style="list-style-type: none"> • The lamp and the lamphouse will be extremely hot while and immediately after using the lamp. • To avoid the risk of burns, do not touch the lamp and the lamphouse while or immediately after using the lamp. • When replacing the lamp, wait for the lamp and the lamphouse to cool sufficiently.
	<p>Biohazard</p> <p>This symbol can be found on the upper part of the microscope, and cautions the following:</p> <ul style="list-style-type: none"> • The product may become biohazardous if a specimen is spilled onto the product. • To avoid exposure to biohazard, do not touch contaminated parts with your bare hands. • Decontaminate the contaminated parts according to the standard procedures for your facility.
	<p>General Caution</p> <p>This symbol can be found on the top of the nosepiece protection plate on Ti-E and Ti-E/B, and on top of the PFS6 nosepiece protection plate on the TI-ND6-PFS PFS Motorized Nosepiece, and cautions the following:</p> <ul style="list-style-type: none"> • To avoid injury (i.e. by getting your fingers caught), be sure to attach the protection plate correctly.

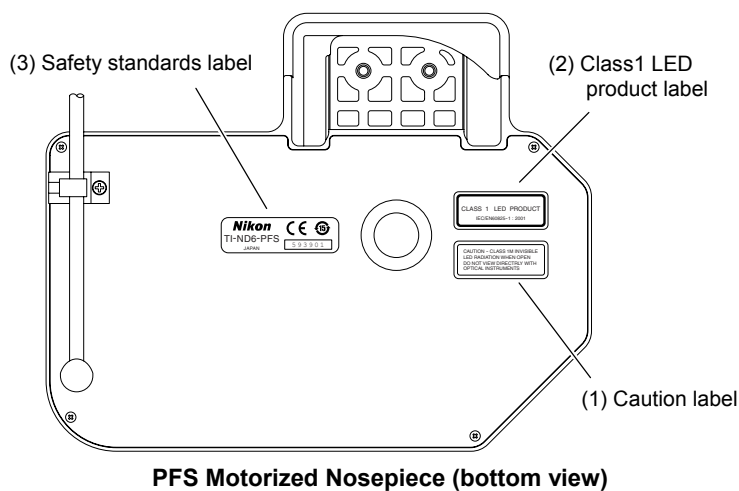
LED Safety

The PFS Motorized Nosepiece (TI-ND6-PFS Perfect Focus Unit) uses light in the near-infrared region (IR wavelength) emitted from an infrared LED to control the focus. When using the PFS Motorized Nosepiece with the product, the microscope system conforms to the EU standard EN60825-1: 2001 and the international standard IEC60825-1: 2001. The product is classified as a Class 1 LED product.

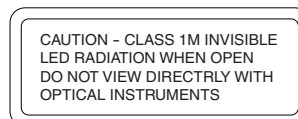
Attempting to control or adjust the product in manners not described in this manual may result in exposure to hazardous LED light.

Safety Labels on TI-ND6-PFS Perfect Focus Unit

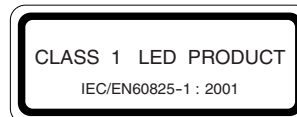
- Safety labels are affixed to the bottom of the TI-ND6-PFS Perfect Focus Unit.



(1) Caution label



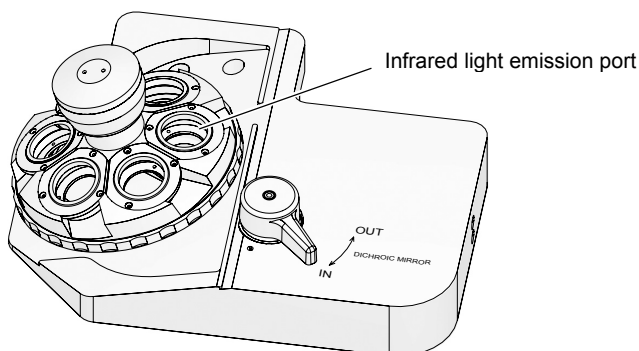
(2) Class 1 LED product label



(3) Safety standards label



- Note that under normal use, infrared light is emitted from the position shown in the figure below.



**Warning****1. Intended application of the product**

The product is intended mainly for microscopic observations and micromanipulations of living cells and tissues under diascopic or episcopic illumination. It is designed for the purposes of experimentations and observations at hospitals or laboratories in the fields of genetics, immunology, physiology, pharmacology, neurology, cellular biology, and molecular biology.

The product is classified as an in-vitro diagnostic medical device.

2. Do not disassemble.

Disassembling this product may result in electric shock or malfunction. Malfunctions and damage due to such mishandlings will not be warranted. Do not disassemble any part that is not indicated in this manual. If you experience problems with the product, contact Nikon.

3. Read the instructions thoroughly.

To ensure safety, thoroughly read this manual and the manuals for other equipment to be used with this product. In particular, be sure to follow the warnings and cautions at the beginning of the manuals.

4. Check the input voltage.

The microscope body uses an AC adapter as its power source. The dia illumination lamp uses one of two types of power supply devices.

• AC adapter for the microscope body:

The AC adapter for the microscope can be used with 100 to 240 VAC at 50-60 Hz, and can be used with most wall outlets in the world. Under normal use, you will not need to pay particular attention to the supplied power voltage.

• TI-PS100W Power Supply:

TI-PS100W Power Supply can be used with 100 to 240 VAC at 50/60 Hz, and can be used with most wall outlets in the world. Under normal use, you will not need to pay particular attention to the supplied power voltage.

• TE-PS30W Power Supply A or TE-PSE30 Power Supply A:

The input voltage ratings are indicated on the rear panel of the power supply device. Before connecting the power cord, check that the indicated input voltage matches the voltage of the wall outlet. If the indicated input voltage does not match your regional voltage supply, do not use the power supply device, and contact Nikon. Use of a power supply device with the inappropriate voltage rating may result in overheating or fire due to overcurrent, and may also cause damage the power supply device and connected devices.

5. Use the specified AC adapter only.

The product is powered by an AC adapter. Be sure to use the specified AC adapter with the product. Use of other AC adapters may result in malfunction, overheat, or fire.

- See Chapter 7, "Specifications" for the specified AC adapter.
- Place the AC adapter in a well-ventilated area to prevent malfunction and fire. Obstacle covering or placed on the AC adapter may hinder the dissipation of heat and cause the AC adapter to become abnormally hot.
- To prevent malfunctions and errors, turn off the POWER switch on the Ti-E or Ti-E/B microscope body (set the POWER switch to the "OFF" side) before connecting the AC adapter.

**Warning****6. Cautions on the power cord**

Be sure to use the specific power cords for the AC adapter and the power supply device. Use of other power cords may result in malfunction, overheat, or fire.

- See Chapter 7, “Specifications” for the specified power cord.
- To prevent electric shock, turn off the power switches on the Ti-E or Ti-E/B microscope body and on the power supply device before connecting or disconnecting the power cord. On Ti-E and Ti-E/B, set the POWER switch to the “OFF” side. On the power supply, set the POWER switch to the “O” side.
- Note that the power supply device is classified as Class I for electric shock protection. Be sure to connect it to a protective ground terminal.

7. Check the combination of dia pillar illuminator, lamp, and power supply device.

The combination of the dia pillar illuminator and the power supply device is specified based on the lamp ratings (12V/100W or 6V/30W) and the power voltage. Use them in the correct combination according to the instructions on page 55. Use of the devices in a wrong combination may result in malfunction, overheat, or fire.

8. Cautions on heat from the light source

The lamp and the lamphouse become extremely hot when the lamp is turned on. Follow the cautions below to prevent burns and fire.

- To avoid burns, do not touch the lamp and the lamphouse while the lamp is on or for approximately thirty minutes after it has been turned off.
- To avoid the risk of fire, do not place fabric, paper, or highly flammable volatile materials (i.e. gasoline, petroleum benzene, paint thinner, and alcohol) near the lamphouse while the lamp is on or for about thirty minutes after it has been turned off.
- Do not block the air vents on the lamphouse. If any obstacle covers the lamphouse or something is placed on the lamphouse, the heat dissipation is inhibited and the lamphouse becomes abnormally hot.
- The bottom of the power supply device becomes hot during use. Do not cover the air vents on the side of the power supply device.

9. Cautions on lamp replacement

- When replacing the lamp, wait approximately thirty minutes after turning off the lamp, and make sure that the lamp and the lamphouse have cooled sufficiently.
- To prevent electric shock and product damage, turn off the power switch on the power supply (set the POWER switch to the “O” side) and unplug the power cord from the wall outlet before replacing the lamp.
- After replacing the lamp, close and secure the lamphouse cover. Never use the product with the lamphouse cover left open.
- Do not break the used lamp. It should be disposed of as an industrial waste, according to the local regulations and rules.

**Warning****10. Cautions on motorized devices**

The product can rotate and focus (raise and lower) the PFS Motorized Nosepiece with motors. The product can also have various motorized devices attached. When TI-HUBC/A Hub Controller A is used with the product, the system can be controlled with a TI series controller or a PC.

To prevent injuries, pay attention to the following when operating motorized devices:

- Before operating the product, check the whole microscope system, and make sure that all moving parts can be operated safely.
- Your hands and fingers may be caught and injured by the nosepiece, objectives, stage, parts arranged on the stage, or specimen containers. Keep your hands away from these devices during operation.
- Check the optical path of the whole microscope system before operating the shutter on the illuminator or adjusting the brightness. The light source emits a very strong light. If the optical path is not set up correctly, the illumination light may leak out or enter the objective, and cause an eye injury.

11. Notes on handling hazardous specimens

The product is intended mainly for microscopic observations and micromanipulations of specimens such as living cells and tissues in a Petri dish. Note the following when handling the specimens:

- Before handling a specimen, check whether it is hazardous. Wear rubber gloves when handling hazardous (i.e. potentially infectious) specimens.
- Be careful not to spill the specimen. If a specimen is spilt onto the microscope, decontaminate according to the standard procedures for your facility.

12. Notes on handling flammable solvents

The following flammable solvents are used with the product:

- Immersion oil (Nikon Immersion Oil for oil immersion objectives)
- Absolute alcohol (ethyl alcohol or methyl alcohol for cleaning optical parts)
- Petroleum benzine (for wiping off the immersion oil)
- Medical alcohol (for disinfecting the microscope)

Never hold a flame near these solvents. When using a solvent, thoroughly read the instructions provided by the manufacturer, and handle correctly and safely. Note the following precautions when using solvents with the product.

- Keep solvents away from the lamp, the lamphouse, the power supply device, and any other parts that may become hot.
- Keep solvents away from the product and its surroundings when turning on/off the power switch or plugging/unplugging the power cord.
- Be careful not to spill the solvents.

**Caution****1. Turn off the power during installation, assembly, connection/disconnection of cables, and maintenance.**

To prevent electric shock and fire, be sure to turn off the power switch on the microscope body and the power supply device (set the POWER switches to the "OFF" side or the "O" side) and unplug the power cords before installing or assembling the product, connecting or disconnecting cables, replacing the lamp, or performing maintenance tasks such as cleaning of the lenses.

2. Do not wet the product or allow intrusion of foreign matters.

Do not wet or spill liquids onto the product, as it may result in malfunction, overheat, or electric shock. If water or other liquids are accidentally spilled onto the product, immediately turn off the power switch (set the POWER switch to the "OFF" side or the "O" side) and unplug the power cord from the wall outlet. Then, wipe off the liquid with a piece of dry cloth. Intrusion of foreign matters into the product may also result in malfunctions. If liquids or foreign matters enter the product, do not use the product, and contact Nikon.

3. Weak electromagnetic waves

The product emits weak electromagnetic waves. Do not install the product near precision electronic devices to avoid affecting their performance. If signal reception by a TV or radio is affected, move the TV or radio set away from the product.

4. Cautions on moving the product

- When carrying the product, hold the product firmly by the bottom front recess and the bottom rear.
- When moving the product, do not hold by the focusing knobs, eyepiece tube, stage, or dia pillar illuminator. The parts may become detached and cause the product to fall, and may also result in malfunctions and loss of precision.

5. Cautions on assembling the product

- Take care to avoid pinching your fingers and hands.
- Scratches and dirt (i.e. fingerprints) on optical components such as lenses and filters will degrade the microscope image. When assembling the product, be careful not to scratch or directly touch the optical components.

6. Cautions on the protruding rack of the Rectangular Mechanical Stage

The stage rack of TI-SR Rectangular Mechanical Stage will protrude when the stage is operated. When operating the focus knobs or the nosepiece, be careful not to strike your hands against the rack. Contact with the edges of the rack may result in injury.

7. Disposal

To avoid biohazard risks, dispose of the product as contaminated equipment, according to the standard procedures for your facility.

Notes on Handling the Product

1. Handle with care.

The product is a precision optical instrument. Handle the product with care and avoid physical shocks and vibrations.

In particular, the precision of objectives may be lost by even weak physical shocks.

2. Installation location and storage location

The product is a precision optical instrument. Use or storage of the product under inappropriate conditions may result in malfunctions or loss of precision. The following conditions must be considered for the installation location and the storage location.

- Install the product in a location with a temperature of 0 to 40°C and a relative humidity of 85% or less (no condensation).
Store the product in a location with a temperature of -20 to 60°C and a relative humidity of 90% or less (no condensation).
Use or storage of the product in a hot or humid location may result in molding of or condensation on the lenses, loss of precision, and malfunctions.
- Install the product in a place with little dust and dirt.
When storing the product, place a cover over the product to protect it from dust.
- Install the product in a place with little vibration.
- Install and store the product on a level and sturdy table or stage that can bear the weight of the product.
Install the product in a location with minimal exposure to hazards in the event of earthquakes and other potential disasters. If necessary, secure the product to the working desk or other heavy and stable items with a strong rope or other means, so as to prevent it from falling.
- Avoid placing the product in direct sunlight or immediately under the room lights.
The image quality is degraded in a bright environment due to the extraneous light entering the objective. A room light immediately above the microscope may also enter the objective as extraneous light, especially when using a condenser lens with a longer working distance (i.e. ELWD and LWD). In this case, it is recommended that you turn off the room light above the microscope.
- Install the product at least 10 cm away from the surrounding walls.
When using TI-DH Dia Pillar Illuminator 100W, install the product at least 15 cm away from the wall, so that the caution labels on the dia pillar illuminator and the lamphouse are visible. Note that TI-DH Dia Pillar Illuminator 100W can be inclined backward to secure working space. To utilize this function, install the product so that there is enough space between the product and the wall for the dia pillar illuminator to be inclined.
- Do not install the product in a closed space such as a locker or a cabinet.
- Do not place items on the product.
- Install the product so that the power cords to the AC adapter and the power supply can be unplugged immediately in case of an emergency.

3. Notes on handling optical parts

Scratches and dirt (i.e. fingerprints) on optical components such as lenses and filters will degrade the microscope image.

Handle the optical components with care, so as not to damage them. If they require cleaning, see Chapter 6, "Daily Maintenance."

4. Notes on handling the lamp

Do not touch the lamp glass with your bare hands. Fingerprints and other dirt on the lamp may result in uneven illumination and reduce the service life of the lamp. Wear gloves or use other pieces of clothes when handling the lamp.

5. Notes on using the focus knobs

- Never rotate the left and right focus knobs on the microscopes in the opposite directions at the same time. Doing so may damage the product.
- Do not rotate the focus knobs past their limit. Doing so may damage the product.

6. Protecting the ports.

The microscope has multiple ports. To keep out extraneous light and dust, attach the provided caps to the ports that are not in use.

7. Caution on motorized devices

Do not force movements on the motorized parts by hand.

8. Note on vibrations caused by motorized operations

This product is designed to minimize the amount of vibration during motorized operation. However, depending on the application, the vibration may have an effect on the microscopy.

9. Note on the Z-axis position display

Ti-E and Ti-E/B microscopes can display the Z-axis position on the front status display panel. Note, however, that the precision of the value is not guaranteed, as Ti-E and Ti-E/B are not designed as measurement machines.

Contents

Introduction	1
Safety Precautions	2
Warning and Caution Symbols in this Manual.....	2
Symbols on the Product	2
LED Safety.....	3
Notes on Handling the Product	8
Contents	11
1. Part Names	12
1.1 Ti-E, Ti-E/B.....	13
1.2 Microscope Base	14
1.2.1 Microscope Base.....	14
1.2.2 Operation Panels.....	15
1.2.3 Connector Panels.....	16
1.3 Eyepiece Base Unit, Eyepiece Tube, and Eyepieces.....	17
1.4 PFS Motorized Nosepiece and PFS Offset Controller	19
1.5 Stage.....	20
1.6 Dia Pillar Illuminator	21
1.6.1 TI-DH Dia Pillar Illuminator 100W.....	21
1.6.2 TI-DS Dia Pillar Illuminator 30W.....	21
1.7 Condenser	22
1.7.1 TI-C Condenser Turret (System Condenser).....	22
1.7.2 ELWD-S Condenser	23
1.8 Power Supply.....	24
1.8.1 TI-PS100W Power Supply.....	24
1.8.2 TE-PS30W Power Supply A (for 100-120V) TE-PSE30 Power Supply A (for 220-240V)	25
1.9 AC Adapter	26
2. Microscopy	27
2.1 Introduction to Microscopy	28
2.2 Bright-Field (BF) Microscopy.....	30
2.3 Phase Contrast (Ph) Microscopy	38
2.4 External Phase Contrast Microscopy	43
2.5 In-focus Observation with PFS.....	49
3. Operation	53
3.1 Power On/Off	54
3.1.1 Power On	54
3.1.2 Power Off	54
3.2 Dia Illumination Operation.....	55
3.2.1 Combination of Lamp, Dia Pillar Illuminator, and Power Supply.....	55
3.2.2 Power Supply Setting	55
3.2.3 Dia Illumination Lamp Operation	56
3.2.4 Brightness Adjustment with ND Filters	56
3.3 Controls on the Microscope Body	57
3.3.1 Front Operation Panel	57
3.3.2 Left Operation Panel	59
3.3.3 Right Operation Panel	60
3.4 Optical Path Selection.....	61
3.4.1 For Ti-E	61
3.4.2 For Ti-E/B	61
3.4.3 Eyepiece Base Unit Options.....	61
3.5 Filter Operation	62
3.6 Field Diaphragm Operation	63
3.7 Aperture Diaphragm Operation	64
3.8 Condenser Operation.....	66
3.8.1 TI-C Condenser Turret (System Condenser).....	66

3.8.2	ELWD-S Condenser	67
3.9	Eyepiece Tube Operation	68
3.9.1	Diopter Adjustment	68
3.9.2	Interpupillary Distance Adjustment	68
3.9.3	Eyepiece Tube Shutter Operation	69
3.9.4	Bertrand Lens Operation	69
3.10	Focusing Mechanism Operation	70
3.10.1	Focus Knob Operation	70
3.10.2	Z-RESET Switch Operation	71
3.10.3	Retraction and Refocusing of Objective	72
3.11	Objective Operation	73
3.11.1	Phase Contrast Objectives	73
3.11.2	Cover Glass Thickness	73
3.11.3	Objectives with Correction Ring	74
3.11.4	Oil Immersion Objectives	75
3.11.5	Water Immersion Objectives	77
3.12	Pillar Illuminator 100W Operation	78
3.12.1	Condenser Refocusing Clamp	78
3.12.2	Condenser Mount Rotation	78
3.12.3	Pillar Inclination	79
3.12.4	Device Attachment Screw Holes	79
3.13	Rectangular Mechanical Stage Operation	80
3.14	PFS (Perfect Focus System) Operation	81
3.14.1	PFS Overview	81
3.14.2	Starting and Stopping In-focus Observation with the PFS	84
3.14.3	Offset Adjustment	86
3.14.4	Registration and Restoration of Offset	87
3.14.5	If the Objective is Changed	88
3.14.6	If the PFS Function Does Not Start	88
4.	Assembly	89
5.	Troubleshooting	118
5.1	Image Viewing	118
5.2	Operation	120
5.3	Electrical System	120
5.4	Perfect Focus System	121
6.	Daily Maintenance	123
6.1	Cleaning Optical Components	123
6.2	Cleaning the Microscope Body	123
6.3	Disinfecting the Microscope	123
6.4	Storage	123
6.5	Periodic Inspections (Paid Service)	123
7.	Specifications	124
7.1	Microscope (Ti-E or Ti-E/B) with TI-DH Dia Pillar Illuminator 100W	124
7.2	Microscope (Ti-E or Ti-E/B) with TI-DS Dia Pillar Illuminator 30W	125
7.3	PFS Motorized Nosepiece and PFS Offset Controller	126
7.4	AC Adapter	128
7.5	Power Cord	128
7.5.1	Power Cord for the AC Adapter	128
7.5.2	Power Cord for the Power Supply	128
7.6	Safety Standards Compliance	129
	System Diagram	130

1

Part Names

This chapter describes the name of each part of the product.

When using the product for the first time, refer to this chapter and check the name and the position of each part. Also refer to this chapter for names and positions of the controls whenever necessary.

- The components of the microscope can be selected to suit the application. However, the lamp, the dia pillar illuminator, and the power supply device must be used in specific combinations. Do not use these devices in an inappropriate combination. For combinations of the lamp, the dia pillar illuminator, and the power supply device, refer to page 55.
- For details on microscopy procedures, see Chapter 2, "Microscopy." For details on the operation of each part, see Chapter 3, "Operation."
- If the microscope has not been assembled yet, first refer to Chapter 4, "Assembly."
- When using the TI-HUBC/A Hub Controller A with the Ti-E or Ti-E/B microscope body, motorized devices can be controlled with an external controller. For details, refer to the instruction manual provided with TI-HUBC/A Hub Controller A.

1.1 Ti-E, Ti-E/B

The illustrations below show the Ti-E microscope body with the following accessories:

TI-DH Dia Pillar Illuminator 100W, TI-C Condenser Turret, D-LH/LC Precentered Lamphouse LC, 12V 100W halogen lamp, TI-PS100W Power Supply, TI-SR Rectangular Mechanical Stage, TI-T-B Eyepiece Base Unit, TI-TD Eyepiece Tube B, CFI 10x eyepieces, TI-ND6-PFS Perfect Focus Unit, objectives, etc.

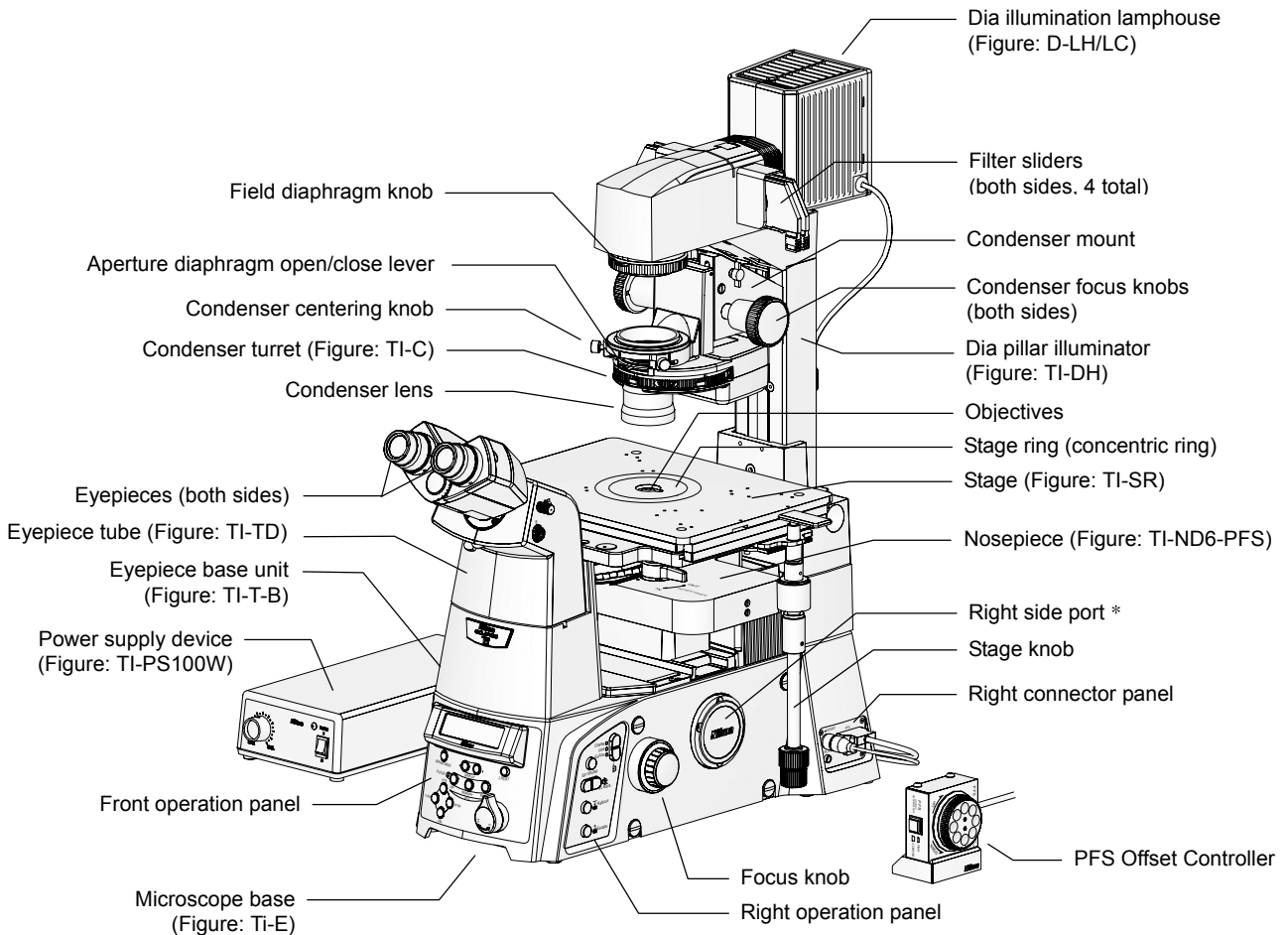


Figure 1-1 Ti-E

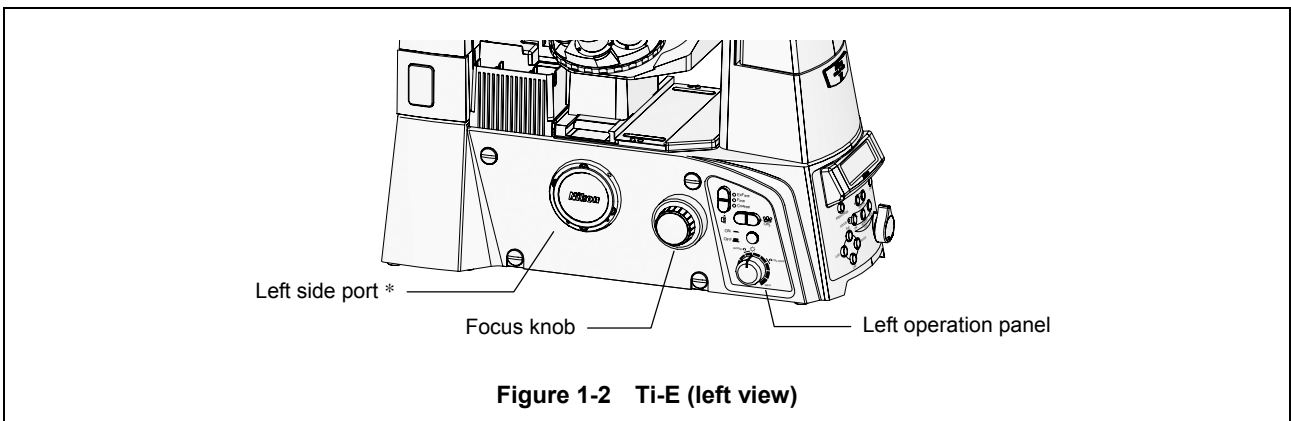


Figure 1-2 Ti-E (left view)

* Attach a protective cap on the side port when the side port is not in use.

1.2 Microscope Base

1.2.1 Microscope Base

To keep out extraneous light and dust, be sure to attach the provided caps to all ports not in use.

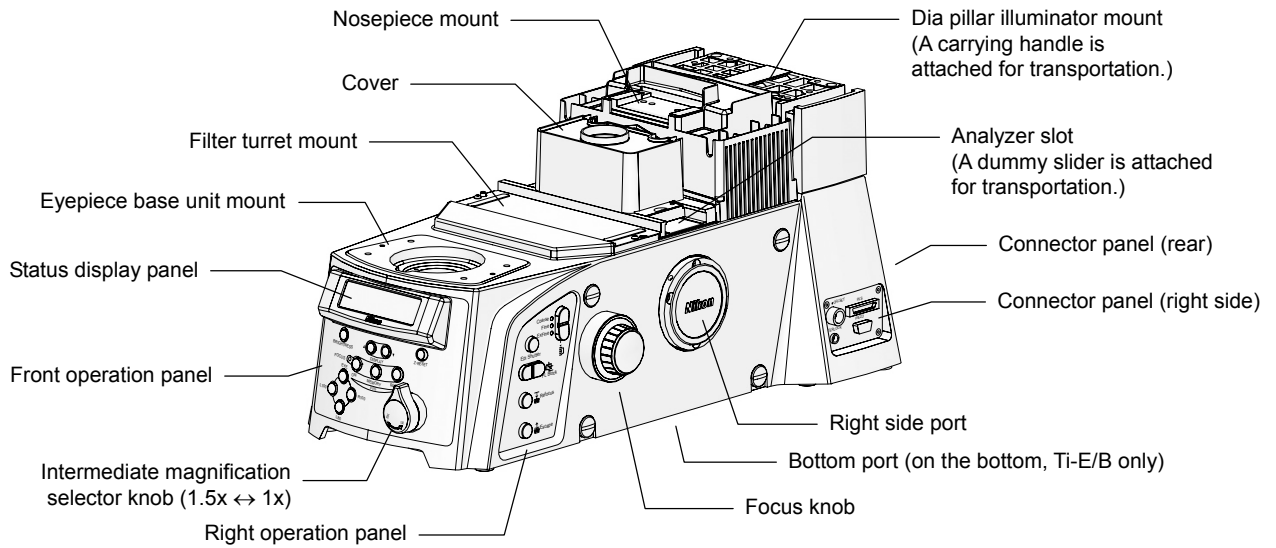


Figure 1-3 Microscope base

Left view

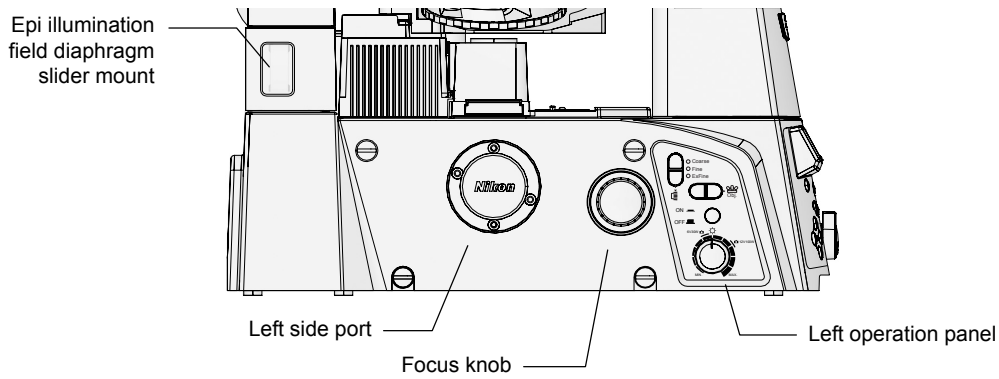


Figure 1-4 Microscope base (left view)

1.2.2 Operation Panels

Front operation panel

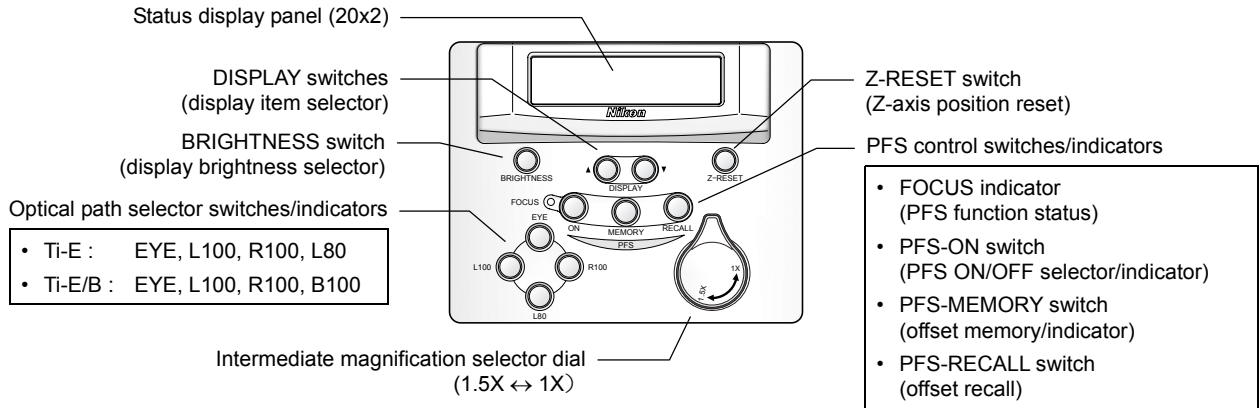


Figure 1-5 Front operation panel

Left operation panel

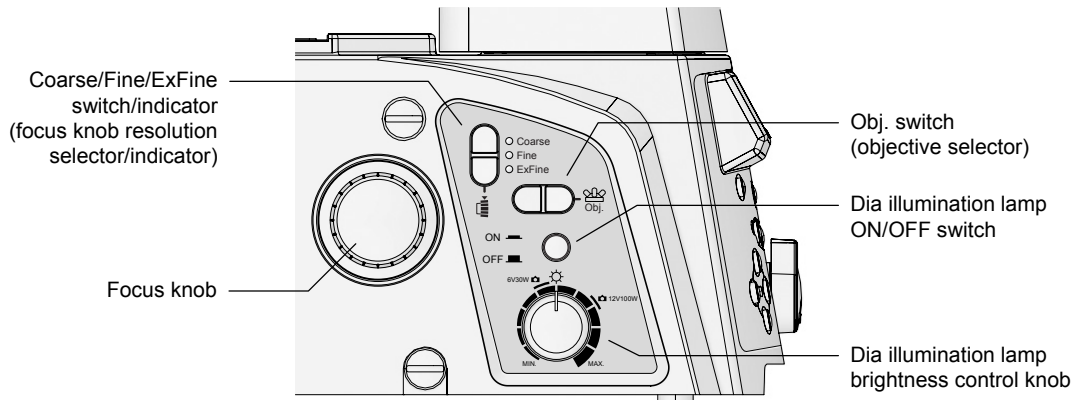


Figure 1-6 Left operation panel

Right operation panel

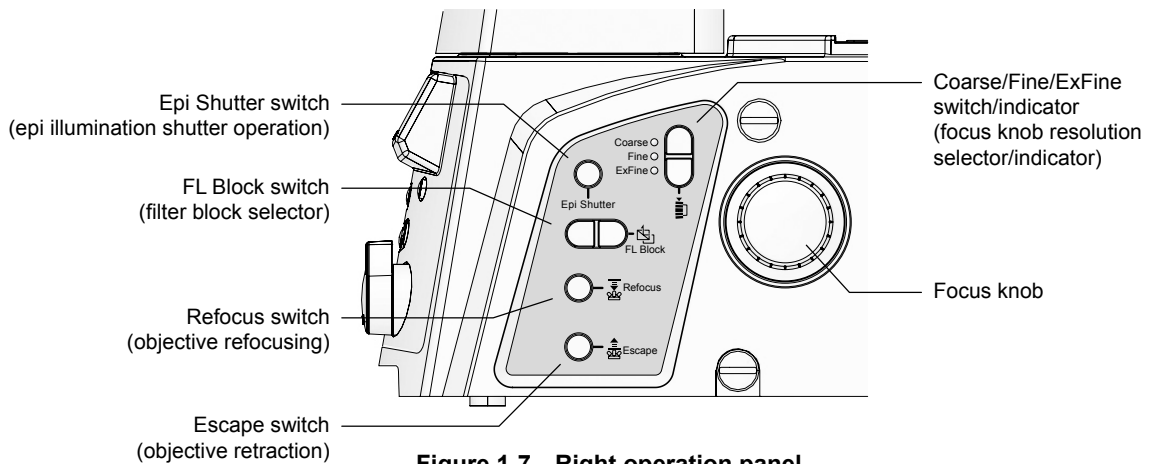


Figure 1-7 Right operation panel

1.2.3 Connector Panels

Right connector panel

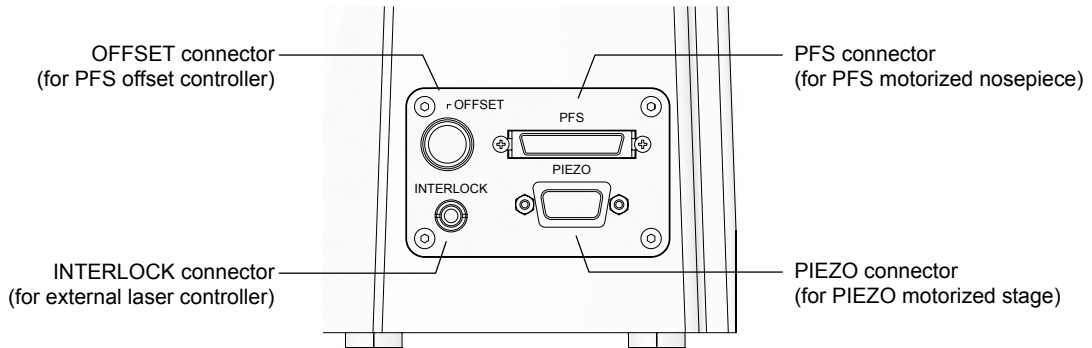


Figure 1-8 Right connector panel

Rear connector panel

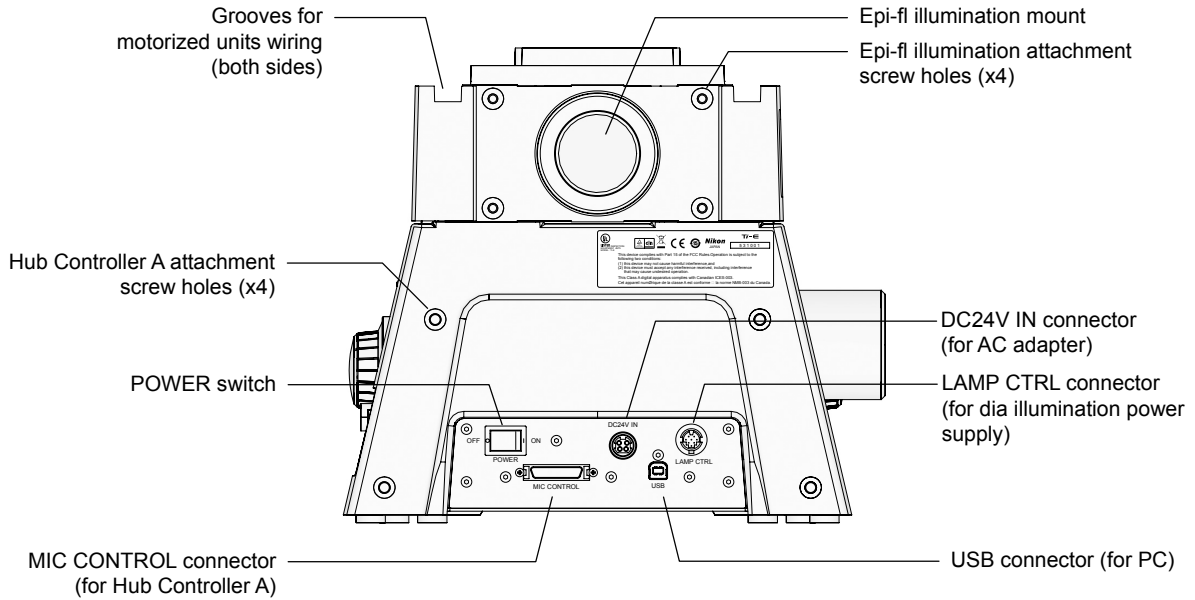


Figure 1-9 Microscope base (rear view)

1.3 Eyepiece Base Unit, Eyepiece Tube, and Eyepieces

The following eyepiece base units, eyepiece tubes, and eyepieces can be mounted on the observation port of the microscope.

TI-T-B Eyepiece Base Unit

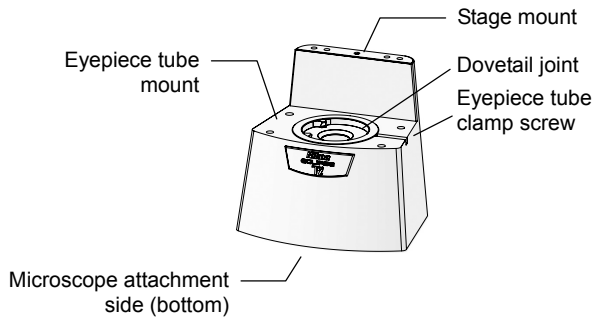


Figure 1-10 TI-T-B Eyepiece Base Unit

This is a basic type eyepiece tube base.

There is a dovetail (truncated cone) joint at the top to attach an eyepiece tube, which is used for visible observation.

If you don't need visible observation, the mount can be left unused. In this case, attach a cover to the dovetail joint.

TI-T-BS Eyepiece Base Unit (with Side Port)

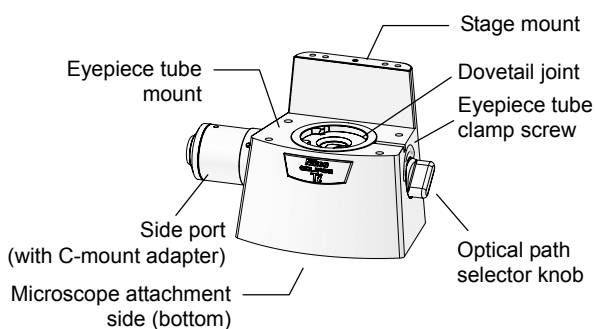


Figure 1-11 TI-T-BS Eyepiece Base Unit (with Side Port)

This is an eyepiece tube base with a camera port.

Use the optical path selector knob at right to change the optical path between the eyepiece side and the side port side.

A direct C-mount adapter is attached to the side port for camera connection.

TI-T-BPH Eyepiece Base Unit (for External Phase Contrast)

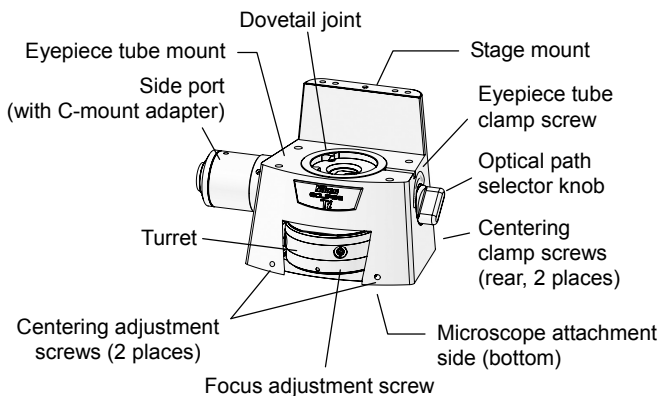


Figure 1-12 TI-T-BPH Eyepiece Base Unit (for External Phase Contrast)

This is an eyepiece tube base for external phase contrast microscopy.

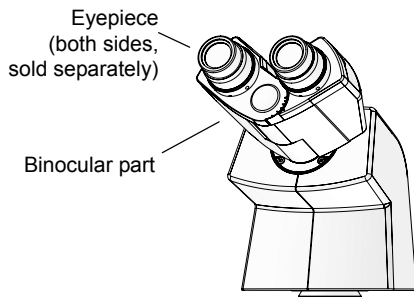
A turret is provided at the front to attach external phase plates. Three positions, "A" to "C", are available. Focus settings can be adjusted for three positions individually. Besides, phase plates can be centered with the screws at both side and clamped with the screw at the back.

A side port with a C-mount adapter is provided at left. Use the optical path selector knob at right to change the optical path between the eyepiece side and the side port side.

Use the side port for photomicroscopy of external phase contrast microscopy.

1.3 Eyepiece Base Unit, Eyepiece Tube, and Eyepieces

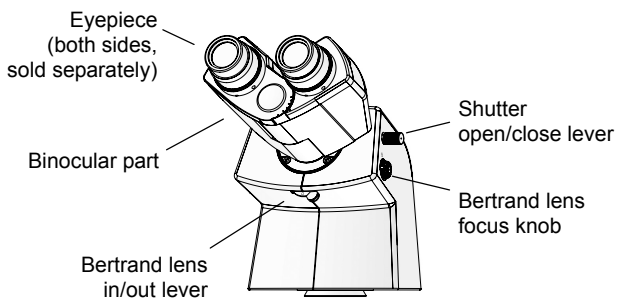
TI-TS Eyepiece Tube B



This is a basic type eyepiece tube.

Figure 1-13 TI-TS Eyepiece Tube B

TI-TD Eyepiece Tube B



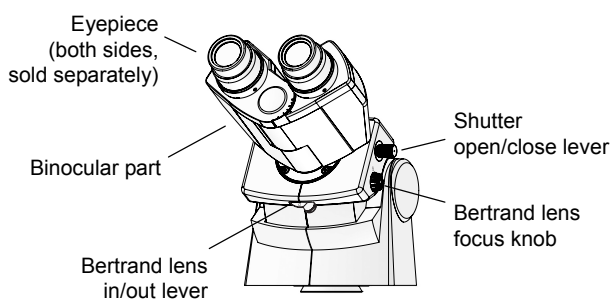
This is an eyepiece tube with a manual shutter and a Bertrand lens.

The optical path for the binocular part can be blocked with the shutter for photomicrography.

Besides, the objective pupil can be observed when the Bertrand lens is placed in the optical path.

Figure 1-14 TI-TD Eyepiece Tube B

TI-TERG Ergonomic Eyepiece Tube



This is an eyepiece tube with a tilt mechanism for user's physical attribute.

This eyepiece tube has a manual shutter and a Bertrand lens. The optical path for the binocular part can be blocked with the shutter for photomicrography. Besides, the objective pupil can be observed when the Bertrand lens is placed in the optical path.

Figure 1-15 TI-TERG Ergonomic Eyepiece Tube

1.4 PFS Motorized Nosepiece and PFS Offset Controller

The PFS Motorized Nosepiece (TI-ND6-PFS Perfect Focus Unit) is an integrated combination of a motorized sextuple DIC nosepiece and a perfect focus system (PFS). The offset can be controlled with the PFS Offset Controller.

PFS Motorized Nosepiece

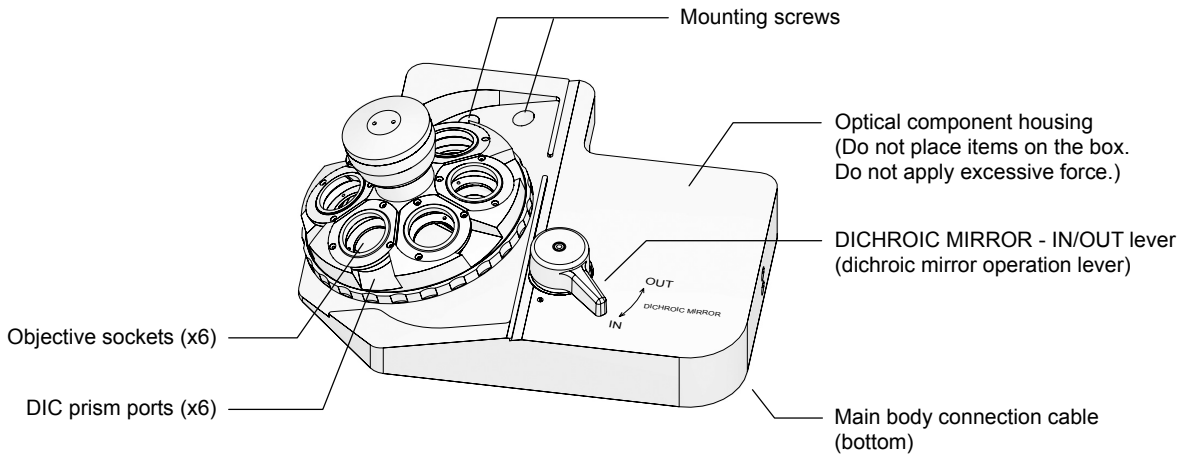


Figure 1-16 PFS Motorized Nosepiece

PFS Offset Controller

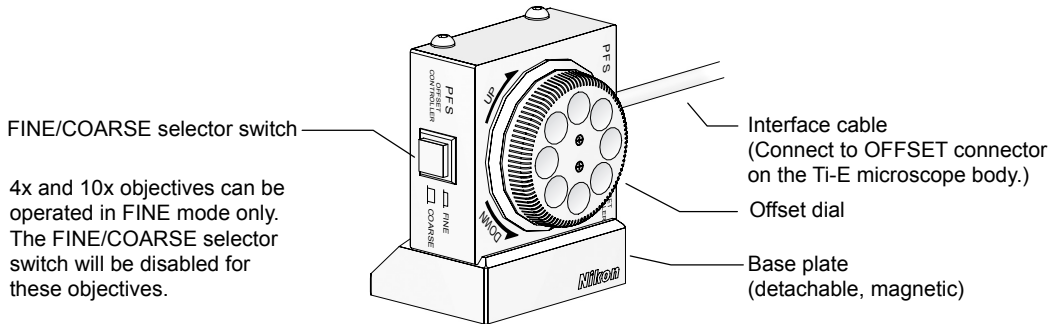


Figure 1-17 PFS Offset Controller

* The offset controller body is magnetically attached to the base plate. Use caution when lifting PFS Offset Controller, as the base plate may become detached and fall.

1.5 Stage

The following stages can be attached to the product.

TI-SR Rectangular Mechanical Stage

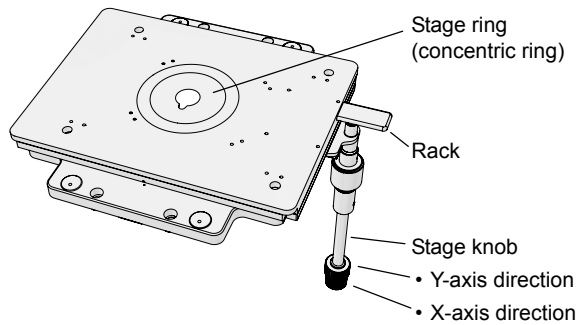
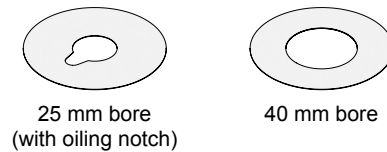


Figure 1-18 Rectangular Mechanical Stage

The specimen can be moved in the X and Y directions by operating the stage knob.

The rectangular mechanical stage comes with two stage clips for culture vessels, and the following two concentric rings.



TI-SP Plain Stage

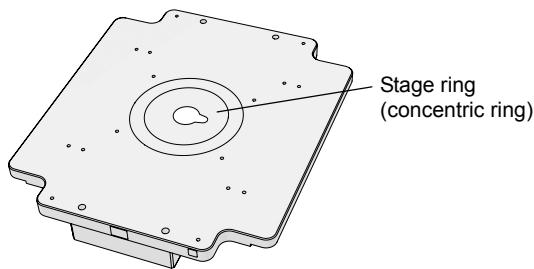
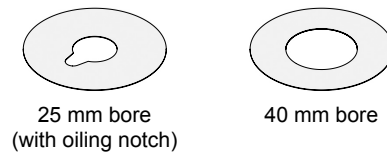


Figure 1-19 Plain Stage

Simple, fixed stage for easy operation of specimens.

The plain stage comes with the following two concentric rings.



TI-SAM Attachable Mechanical Stage

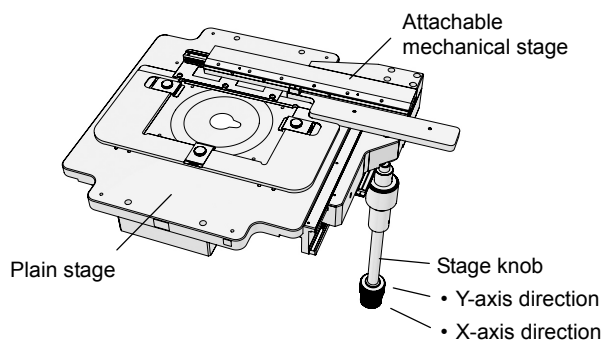


Figure 1-20 Attachable Mechanical Stage (on Plain Stage)

This stage is attached to the plain stage when using specimen holders. The specimen can be moved in the X and Y directions by operating the stage knob.

Various specimen holders can be used by attaching the following adapters to the provided microplate.

- MA60 microplate holder
- MA60 Petri dish holder
- MA glass slide holder
- 35 Petri dish holder

1.6 Dia Pillar Illuminator

Ti series microscopes can be used with the following two types of dia pillar illuminators. The two dia pillar illuminators differ in lamp rating (12V 100W or 6V 30W) and support different microscopy methods. Select the dia pillar illuminator to suit your application.

1.6.1 TI-DH Dia Pillar Illuminator 100W

The TI-DH Dia Pillar Illuminator 100W is used with a separate lamphouse and condenser. The following illustration shows the TI-DH Dia Pillar Illuminator 100W with the D-LH/LC Precentered Lamphouse and the TI-C Condenser Turret (System Condenser) attached.

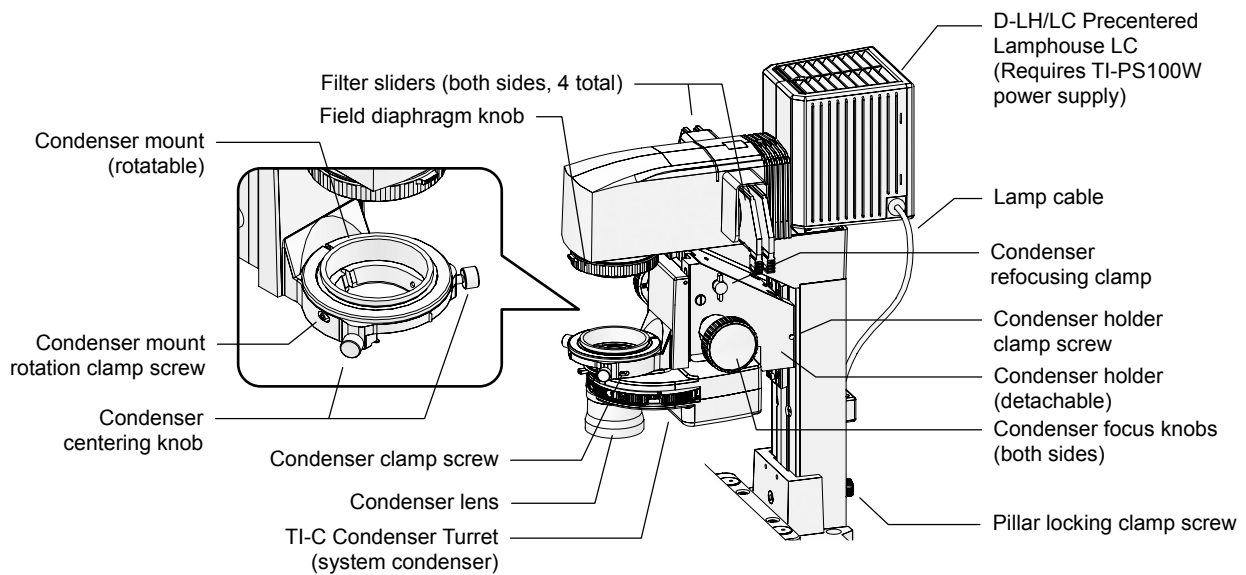


Figure 1-21 TI-DH Dia Pillar Illuminator 100W (with lamphouse and system condenser)

1.6.2 TI-DS Dia Pillar Illuminator 30W

The TI-DS Dia Pillar Illuminator 30W has a built-in lamphouse, but requires a separate condenser. The following illustration shows the TI-DS Dia Pillar Illuminator 30W with the ELWD-S Condenser.

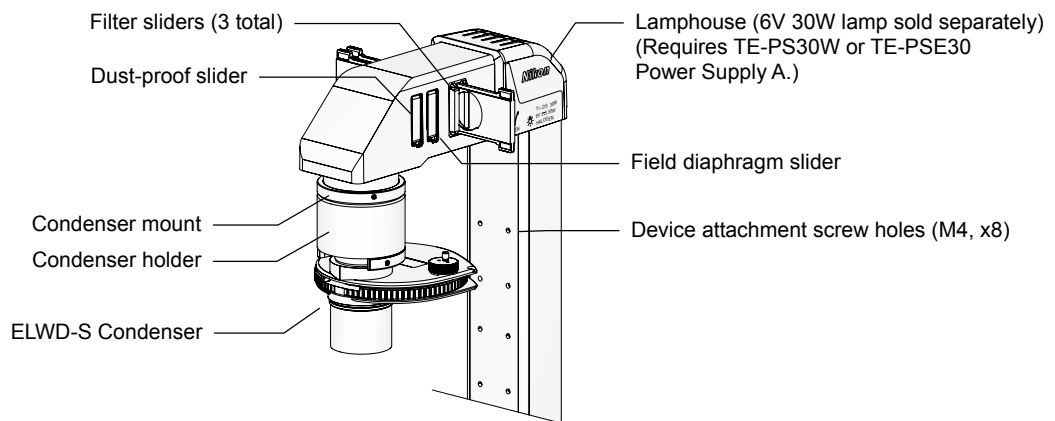


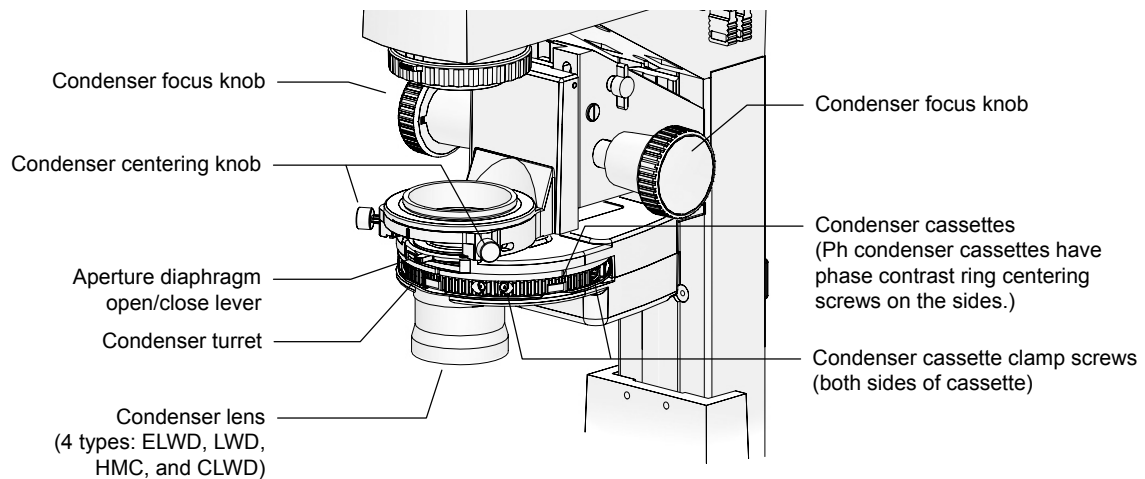
Figure 1-22 TI-DS Dia Pillar Illuminator 30W (with ELWD-S Condenser)

1.7 Condenser

1.7.1 TI-C Condenser Turret (System Condenser)

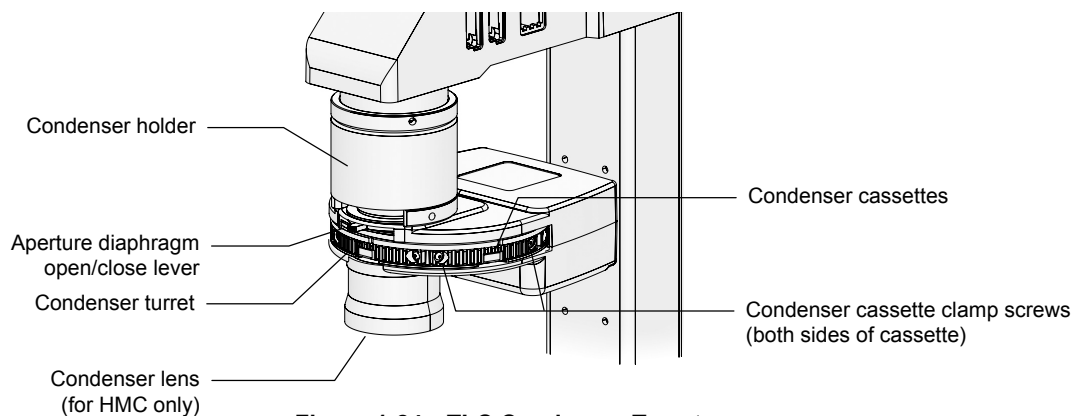
The TI-C Condenser Turret allows you to attach various optical elements to a turret and select them as necessary for different microscopy methods. This type of condenser is referred to as a “system condenser”.

System condenser (mounted on TI-DH Dia Pillar Illuminator 100W)



**Figure 1-23 TI-C Condenser Turret
(mounted on TI-DH Dia Pillar Illuminator 100W)**

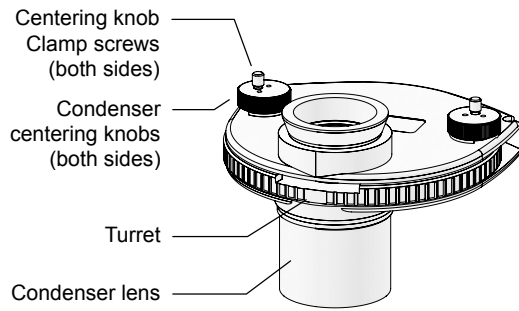
System condenser (mounted on TI-DS Dia Pillar Illuminator 30W)



**Figure 1-24 TI-C Condenser Turret
(mounted on TI-DS Dia Pillar Illuminator 30W)**

* The system condenser can be mounted on the TI-DS Dia Pillar Illuminator 30W for HMC observation only.

1.7.2 ELWD-S Condenser



The ELWD-S Condenser supports bright-field microscopy and phase contrast microscopy. It can be used with both 100W and 30W dia pillar illuminators.

Figure 1-25 ELWD-S Condenser

1.8 Power Supply

1.8.1 TI-PS100W Power Supply



Warning

The bottom of the power supply device becomes hot during use. Do not block the air vents on the side of the product.

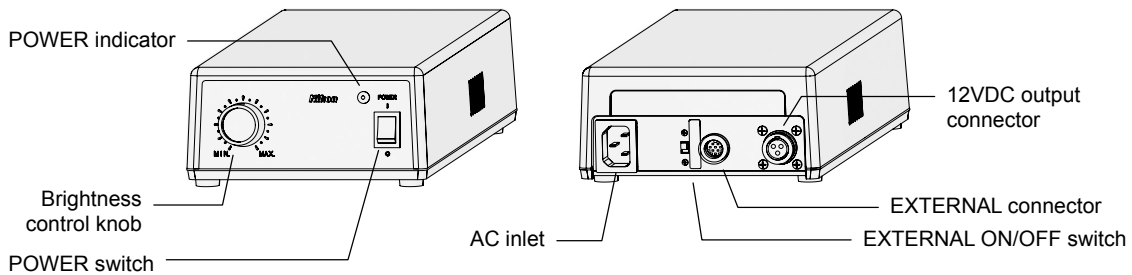


Figure 1-26 TI-PS100W Power Supply

POWER switch

This is the power switch for the power supply. Press the “I” side of the switch to turn on the power supply and output DC power from the 12VDC output on the rear. Press the “O” side of the switch to turn off the power supply.

POWER indicator

Lit when the power supply is on.

Brightness control knob

When the EXTERNAL switch is turned off, the knob controls the brightness of the lamp by adjusting the voltage supplied from the 12VDC output connector.

AC inlet

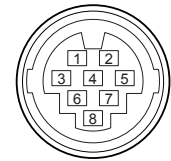
This is the connector for connecting the power supply device to a wall outlet. Be sure to use the specified power cord for the connection.

EXTERNAL (external control) ON/OFF switch

Turn this switch on to use the brightness control knob on the microscope for output voltage control. When this switch is turned off, the brightness control knob on the front of the power supply becomes enabled, and the brightness control knob on the microscope becomes disabled.

EXTERNAL (external control signal input) connector

Connect the control cable to this connector and the LAMP CTRL connector on the rear of the microscope.

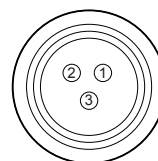


Pin	Signal
1	External resistor terminal for output voltage adjustment
2	External resistor terminal for output voltage adjustment
3	Output voltage ON/OFF switch (input)
4	GND (0V)
5	External voltage input for output voltage adjustment
6	EXTERNAL switch on/off detect signal (output)
7	GND (0V)
8	Output voltage monitor terminal (output)

Connector: HR12-10R-8SC by Hirose Electric Co., Ltd.

12VDC output connector

This connector supplies power to the 12V 100W halogen lamp. Connect the lamp cable for the pillar illuminator.



Pin	Signal
1	Output +
2	Output -
3	Not used

Connector: SRCN2A13-3S by Japan Aviation Electronics Industry, Ltd.

1.8.2 TE-PS30W Power Supply A (for 100-120V) TE-PSE30 Power Supply A (for 220-240V)



Warning

- Before turning on the power supply, check that the input voltage indicator matches the power voltage in your area. If the voltages do not match, do not turn on the product, and contact Nikon. Use of the product under a wrong voltage may result in malfunction or fire.
- The bottom of the power supply device becomes hot during use. Do not block the air vents on the side of the product.

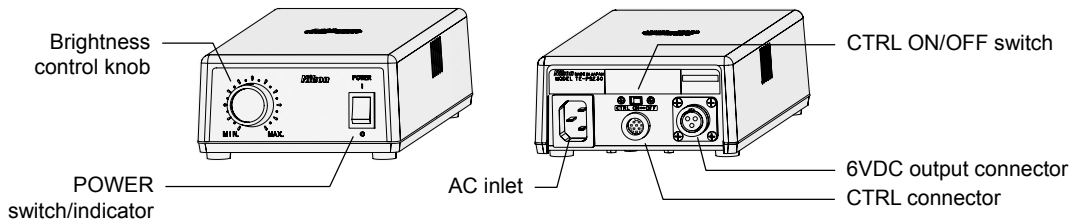


Figure 1-27 TE-PS30W, TE-PSE30 Power Supply A

POWER switch/indicator

This is the power switch for the power supply. Press the “I” side of the switch to turn on the power supply and output DC power from the 6VDC output on the rear. The switch is lit when the power supply is on. Press the “O” side of the switch to turn off the power supply.

Brightness control knob

When the CTRL switch is turned off, this knob controls the brightness of the lamp by adjusting the voltage output from the 6VDC output connector.

AC inlet

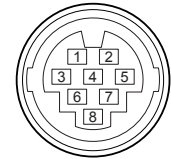
This is the connector for connecting the power supply device to a wall outlet. Be sure to use the specified power cord for the connection.

CTRL (external control) ON/OFF switch

Turn this switch on to use the brightness control knob on the microscope for output voltage control. When this switch is turned off, the brightness control knob on the front of the power supply becomes enabled, and the brightness control knob on the microscope becomes disabled.

CTRL (external control signal input) connector

Connect the control cable to this connector and the LAMP CTRL connector on the rear of the microscope.

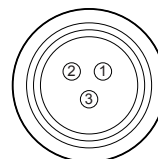


Pin	Signal
1	External resistor terminal for output voltage adjustment
2	External resistor terminal for output voltage adjustment
3	Output voltage ON/OFF switch (input)
4	GND (0V)
5	Not used
6	Not used
7	Not used
8	Not used

Connector: HR12-10R-8SC by Hirose Electric Co., Ltd.

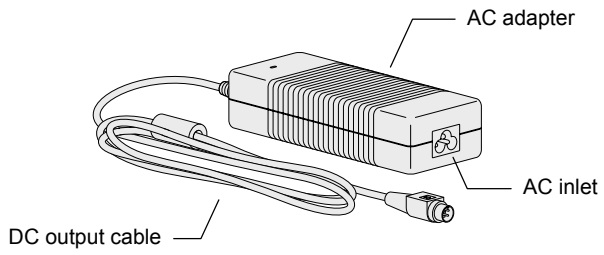
6VDC output connector

This connector supplies power to the 6V 30W halogen lamp. Connect the lamp cable for the pillar illuminator.



Pin	Signal
1	Output -
2	Not used
3	Output +

Connector: SRCN2A13-3S by Japan Aviation Electronics Industry, Ltd.

1.9 AC Adapter**Figure 1-28 AC adapter**

Power to the microscope is supplied via an AC adapter.

The AC adapter can be used with 100 to 240 VAC at 50-60 Hz, and can be used with most wall outlets in the world.

- Use the AC adapter included with the product.
- Use a power cord specified in Chapter 7, "Specifications".

2

Microscopy



Warning

- Before using the product, thoroughly read the “Safety Precautions” at the beginning of this manual, and heed all warnings and cautions written therein.
- To use other equipment such as epi-fl attachment or differential interference contrast attachment, refer to the respective manuals and heed all warnings and cautions written therein.



Caution

When using the PFS Motorized Nosepiece, use the “Ti Control” setup software for Ti series to register the objective information from a PC. PFS Motorized Nosepiece will not function properly unless the objective information has been registered correctly. For details on using “Ti Control”, refer to the “Ti Control” instruction manual.

When using Ti-E or Ti-E/B with
TI-HUBC/A Hub Controller A attached on the back



Refer to the instruction manual provided with TI-HUBA/B Hub Controller A

The TI-HUBC/A Hub Controller A is used to control the motorized components.

When the TI-HUBC/A Hub Controller A is attached to the back of the microscope, operation procedures for the motorized devices will change. Refer to the instruction manual for the TI-HUBC/A Hub Controller A, and prepare and observe accordingly.

Note that the following two operations cannot be performed electrically even if the TI-HUBC/A Hub Controller A is attached:

- **6V 30W lamp operation:** Use the dia illumination lamp ON/OFF switch.
- **6V 30W lamp voltage adjustment:** Use the brightness control knob on the microscope body or on the power supply device.

2.1 Introduction to Microscopy

The Ti series microscopes are system microscopes that offer a high degree of flexibility in system building for various purposes. A wide range of options is available for various parts, including the main body, dia illuminator, and eyepiece tube. For this reason, the operation procedures will vary depending on the system configuration.

In this chapter, the following common configuration is used as an example to explain the microscopy procedures.

Sample configuration

Ti-E, PFS Motorized Nosepiece, TI-DH Dia Pillar Illuminator 100W, LWD Condenser, and TI-TD Eyepiece Tube B

Bright-field microscopy (see 2.2)

Phase contrast microscopy (without external phase contrast devices) (see 2.3)

External phase contrast microscopy (see 2.4)

In-focus observation with PFS (see 2.5)

- For the name and position of each part, refer to Chapter 1, “Part Names.”
- For details on operation methods, refer to Chapter 3, “Operation.”
- If the microscope has not been assembled yet, first refer to Chapter 4, “Assembly.”
- If the configuration of your microscope system differs from the examples used in this chapter, refer to the relevant sections of Chapter 3, “Operation.”
- If your microscope system has the epi-fl attachment or the differential interference contrast attachment, refer to the respective instruction manuals.
- If your microscope system is equipped with the TI-HUBC/A Hub Controller A, refer to the instruction manual provided with the hub controller.

Sample configuration

This section describes the microscopy procedures under the assumption that the following devices are attached to the microscope.

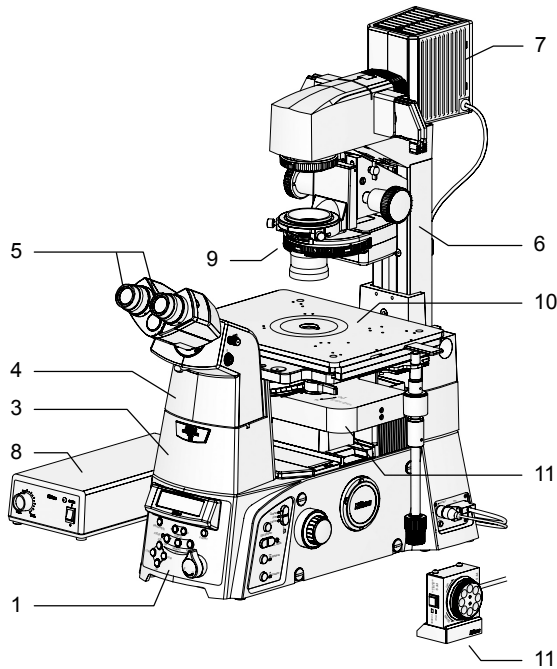


Figure 2-1 Sample configuration

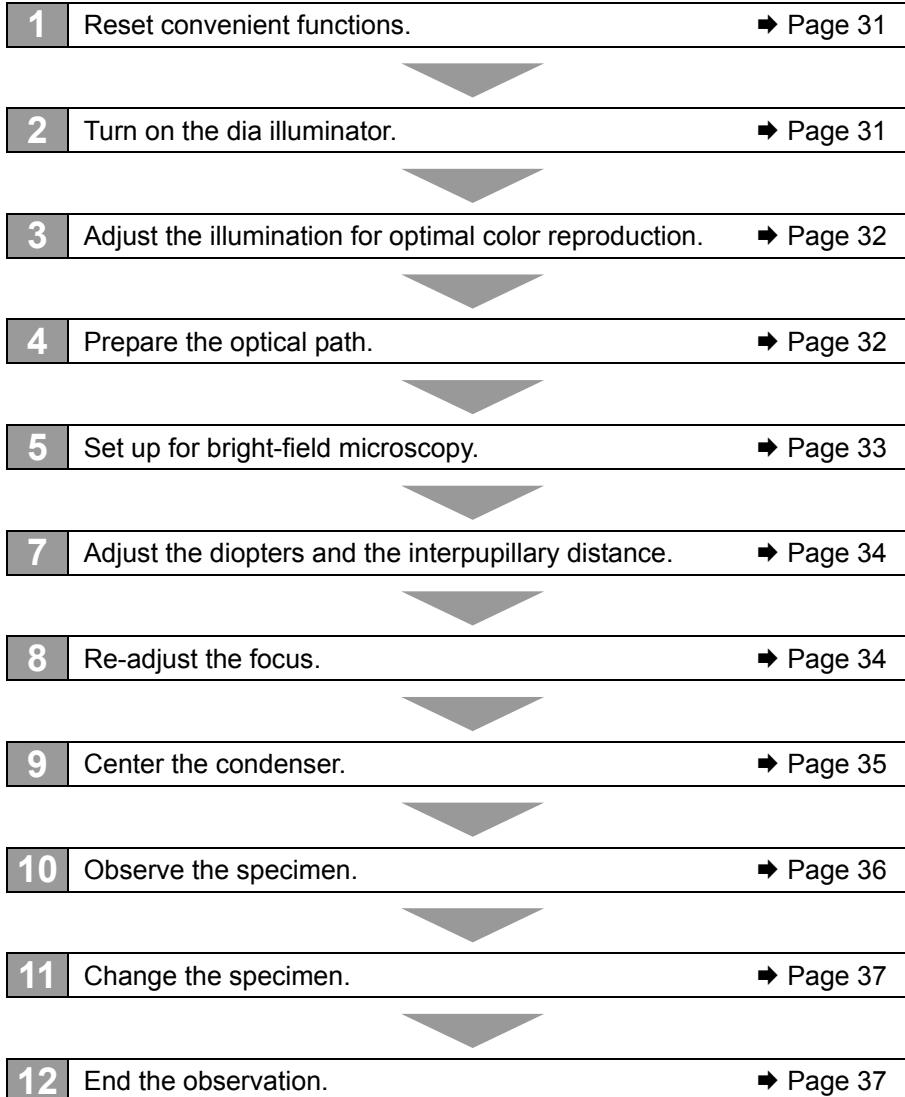
1. Ti-E microscope body
2. AC adapter, power cord *
3. TI-T-B Eyepiece Base Unit
4. TI-TD Eyepiece Tube B
5. CFI 10x eyepiece (x2)
6. TI-DH Dia Pillar Illuminator 100W, filters (NCB11, ND4, GIF)
7. D-LH/LC Precentered Lamphouse LC, 12V 100W Halogen Lamp
8. TI-PS100W Power Supply, power cord
9. TI-C Condenser Turret, LWD Condenser Lens, condenser cassette for bright-field microscopy, condenser cassette for phase contrast microscopy
10. TI-SR Rectangular Mechanical Stage
11. TI-ND6-PFS PFS Motorized Nosepiece, PFS Offset Controller, 10x and 40x objectives, phase contrast objective

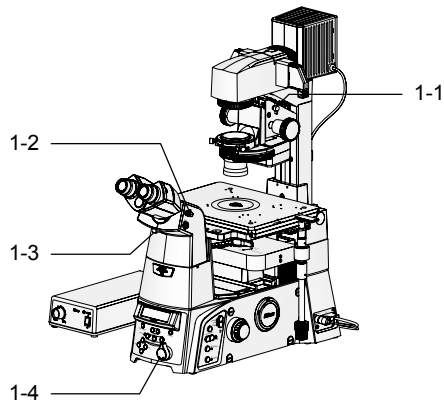
* "2. AC adapter, power cord" not shown in Figure 2-1.

2.2 Bright-Field (BF) Microscopy

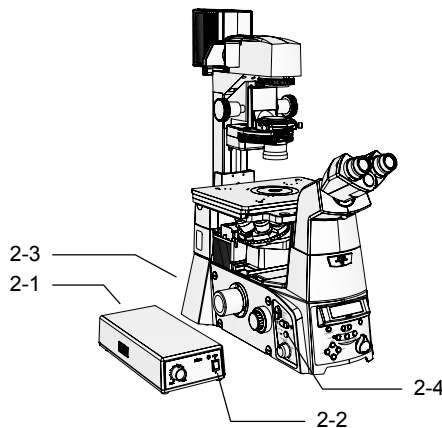
Bright-field (BF) microscopy workflow

Outline: Remove all unnecessary optical elements from the optical path. Focus and center the condenser. Adjust the aperture diaphragm for a better image.



1 Reset convenient functions.

1. Release the condenser refocusing clamp on the dia pillar illuminator by rotating it counterclockwise.
2. Open the shutter at the eyepiece by pushing in the shutter operation lever on the right side of the eyepiece tube.
3. Move the Bertrand lens out of the optical path by moving the Bertrand lens operation lever on the front of the eyepiece tube to position "O".
4. Rotate the intermediate magnification selector dial on the front of the microscope to the "1x" side.

2 Turn on the dia illuminator.

1. Set the EXTERNAL switch on the back of the power supply to "ON".
2. Turn on the power supply by pressing the "I" side of the POWER switch on the power supply.
3. Turn on the Ti-E microscope by pressing the "ON" side of the POWER switch on the back of the microscope.
The Ti-E microscope is turned on, and the current status is displayed on the status display panel.
4. Turn on the lamp by pressing the dia illumination lamp ON/OFF switch on the left side of the microscope.

The display content of the status display panel can be switched between the following three screens by pressing the DISPLAY switch. Switch the screen as necessary to display the information required for the operation.

■ Display content of the status display panel

```
Z: 0.000um
E100 Coarse
```

- Upper: Z-axis position
- Lower: Optical path | Focus knob resolution

```
10x/0.25
E100 Coarse PFS:Out.
```

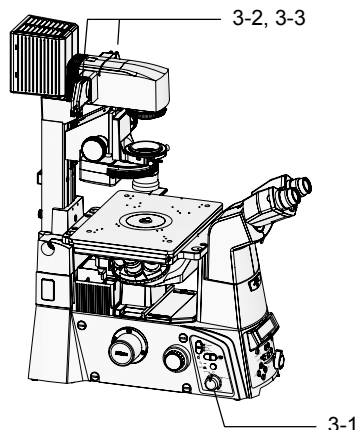
- Upper: Objective data
- Lower: Optical path | Focus knob resolution | PFS

```
10x Z: 0.000um
E100 Coarse PFS:Out.
```

- Upper: Magnification | Z-axis position
- Lower: Optical path | Focus knob resolution | PFS

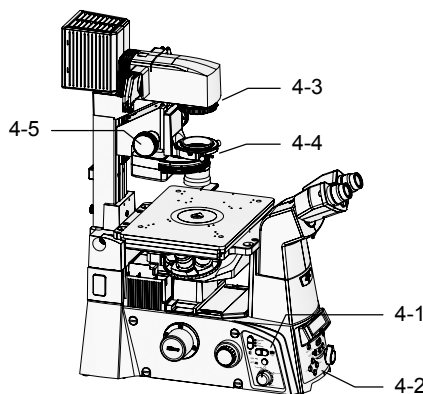
* Additional display patterns will become available when using motorized option devices. For details of the display content, refer to the instruction manual provided with Hub Controller A.

3 Adjust the illumination for optimal color reproduction.



1. Rotate the brightness control knob on the left side of the microscope to the “12V100W” position.
2. Move the NCB11 filter on the dia pillar illuminator into the optical path.
3. Move the ND4 filter on the dia pillar illuminator into the optical path.

4 Prepare the optical path.



1. Move the 10x objective into the optical path by pressing the Obj. switch on the left operation panel.

The status display panel can be used to confirm which objective is in the optical path.

■ Display example for objective (10x, NA 0.25)

```
10x/0.25
E100 Coarse PFS:Out
```

2. Direct a 100% light towards the eyepiece observation port by pressing the EYE switch on the front operation panel.

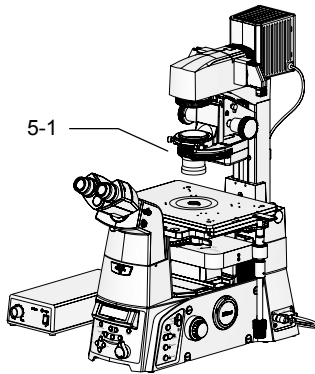
The selected switch will light up in green, and the port name “E100” will be displayed on the status display panel.

■ Display example for output port

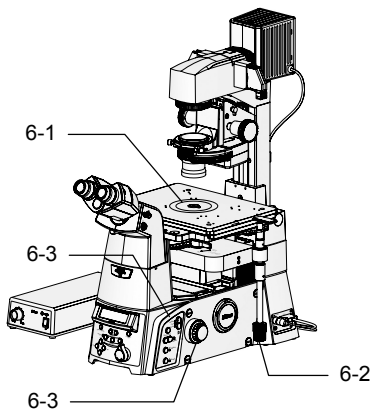
```
Z: 0.000um
E100 Coarse
```

3. Fully open the aperture diaphragm by rotating the aperture diaphragm knob on the dia pillar illuminator clockwise to the limit.
4. Fully open the aperture diaphragm by moving the aperture diaphragm open/close lever on the system condenser to the limit.
5. Lower the condenser mount to the limit by rotating the condenser focus knob on the dia pillar illuminator.

- If an ELWD condenser lens is attached to the system condenser, place the condenser mount 1 cm below the upper limit.
- If using the ELWD-S condenser, position the condenser mount approximately 2 cm below the upper limit.

5 Set up for bright-field microscopy.

1. Move the condenser cassette for bright-field microscopy into the optical path by rotating the condenser turret to position "A".

6 Set specimen and adjust the focus.

1. Place the specimen onto the stage.
2. Move the stage to bring the observation target into the center of the field of view.
3. Look into the eyepiece. Adjust the focus onto the specimen by using the Coarse/Fine/ExFine switches and the focus knobs on the sides of the microscope.

Use the Coarse/Fine/ExFine switches to change the focus knob resolution (speed of vertical movement) for easier focus adjustment. There are three resolutions: Coarse, Fine, and ExFine (extra fine). The current setting will be displayed by an indicator.

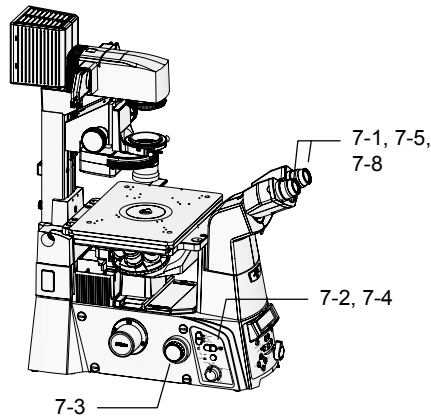
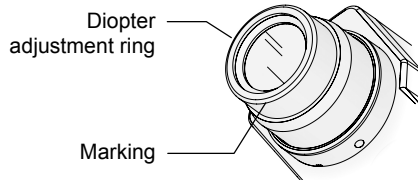
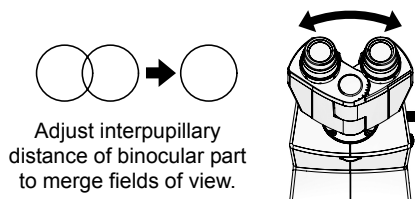
Focus knob resolution and Z-axis position can be displayed on the status display panel.

■ Display example for focus knob resolution and Z-axis position

```
Z: +124.225um
E100 Fine
```

The Z-axis position information on the status display panel can be reset to zero by pressing the Z-RESET switch on the front operation panel.

By pressing the Z-RESET switch when the focus is on the specimen, you will be able to use the Z-axis position value as reference when readjusting the focus.

7 Adjust the diopters and the interpupillary distance.**Diopter adjustment on eyepieces****Interpupillary adjustment on binocular**

1. On each eyepiece, rotate the diopter adjustment ring to align its lower end with the marking on the eyepiece.

This will be the reference position for diopter adjustment.

2. Move the 40x objective into the optical path by pressing the Obj. switch.
3. Look into the left eyepiece with your left eye. Adjust the focus onto the specimen by rotating the focus knobs.

Use the Coarse/Fine/ExFine switches to change the focus knob resolution for easier focus adjustment.

4. Move the 10x objective into the optical path by pressing the Obj. switch.
5. Look into the left eyepiece with your left eye. Adjust the focus onto the specimen by rotating the diopter adjustment ring on the left eyepiece.

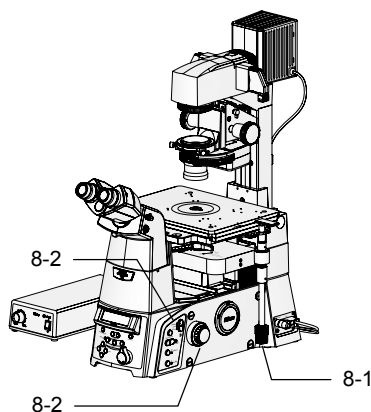
Do not touch the focus knobs at this time.

6. Repeat steps 2 through 5 two times.

7. Adjust the right eyepiece.

Repeat steps 2 through 6, but this time using the right eyepiece instead of the left.

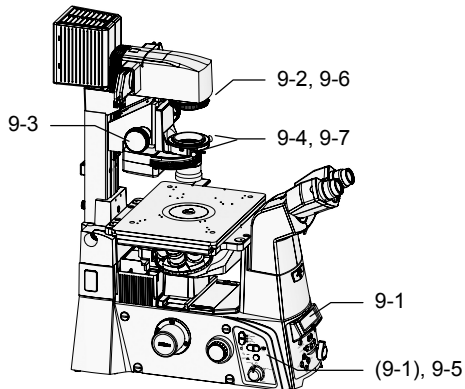
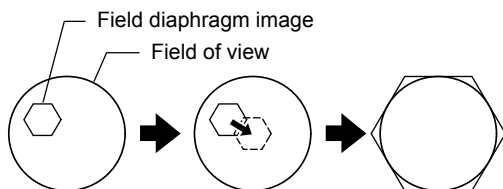
8. Adjust the interpupillary distance of the binocular part to merge the two fields of view.

8 Re-adjust the focus.

1. Look into the eyepiece. Move the stage to bring the observation target into the center of the field of view.

2. Focus on the target by rotating the focus knobs.

Use the Coarse/Fine/ExFine switches to change the focus knob resolution for easier focus adjustment.

9 Center the condenser.**Field diaphragm adjustment**

Move field diaphragm image into center of field of view. Adjust its size to match field of view.

1. Check that the 10x objective is in the optical path.

The status display panel can be used to confirm which objective is in the optical path.

- Display example for objective (10x, NA 0.25)

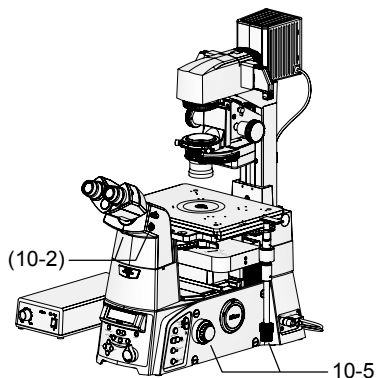
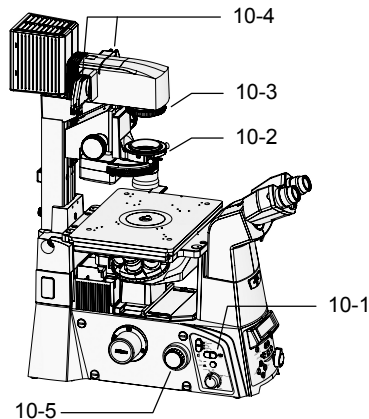
```

10x/0.25
E100 Coarse PFS:Out

```

If not, move the 10x objective into the optical path by pressing the Obj. switch on the left side of the microscope.

2. Rotate the field diaphragm knob on the dia pillar illuminator until the field diaphragm image is visible in the field of view.
3. Adjust the focus onto the field diaphragm image by rotating the condenser focus knob on the dia pillar illuminator.
4. Move the field diaphragm image to the center of the field of view by turning the two condenser centering screws on the dia pillar illuminator.
5. Move the 40x objective into the optical path by pressing the Obj. switch.
6. Adjust the size of the field diaphragm image to closely match the size of the field of view, by rotating the field diaphragm knob on the dia pillar illuminator.
7. Move the field diaphragm image to the center of the field of view by turning the two condenser centering screws on the dia pillar illuminator.

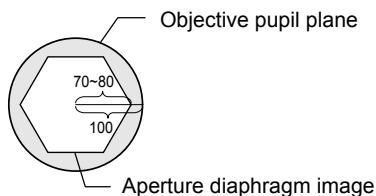
10 Observe the specimen.

1. Move an objective with the desired magnification into the optical path by pressing the Obj. switch.
2. Adjust the size of the aperture diaphragm to "70-80% the size of the NA of the objective" by moving the aperture diaphragm open/close lever on the system condenser.

Move the Bertrand lens into the optical path by moving the Bertrand lens in/out lever on the eyepiece tube to position "B". This will allow you to observe the objective pupil plane and the aperture diaphragm image. Adjust the focus by rotating the Bertrand lens focusing knob on the right side of the eyepiece tube, and then adjust the size of the aperture diaphragm image to 70-80% the size of the objective pupil plane.

When done, move the Bertrand lens out of the optical path by moving the operation lever to position "O".

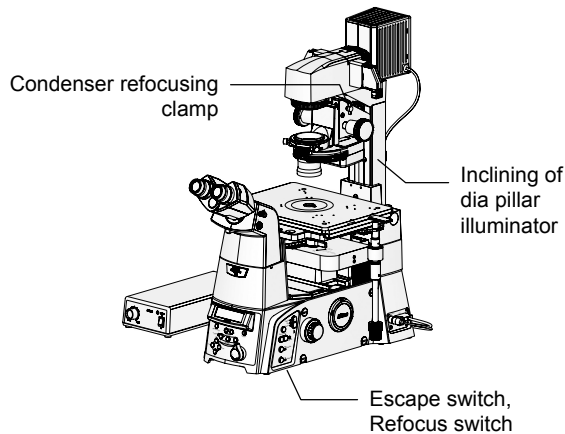
3. Adjust the size of the field diaphragm image to closely match the size of the field of view, by rotating the field diaphragm knob on the dia pillar illuminator.
4. Adjust the brightness for the field of view by moving the ND filters on the dia pillar illuminator in and out of the optical path.

Aperture diaphragm adjustment

Adjust the size of the aperture diaphragm image to 70-80% the size of the objective pupil plane.

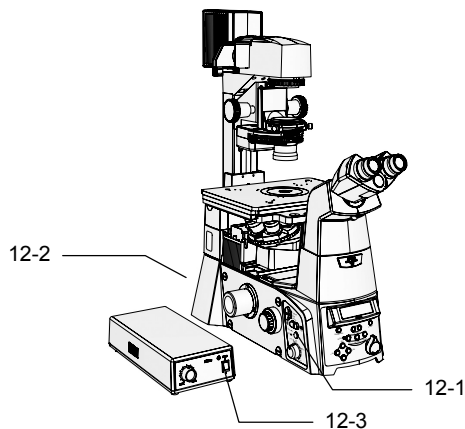
If color reproducibility is not required, brightness adjustment can be performed by changing the lamp voltage with the brightness control knob on the left side of the microscope.

5. Move the stage to bring the observation target into the center of the field of view. Adjust the focus by rotating the focus knobs.

11 Change the specimen.

Use the following functions as necessary.

- **Inclining of dia pillar illuminator**
When using the 100W dia pillar illuminator, the entire dia pillar illuminator can be inclined backward by loosening the fixing knob on its back side, so as to secure more working space.
- **Escape switch, Refocus switch**
If there is a need to lower the objective, the objective can be retracted temporarily by pressing the Escape switch on the right operation panel.
To return the objective to approximately the same height, press the Refocus switch without rotating the focus knobs.
- **Condenser refocusing clamp**
If there is a need to move the condenser up and down, tighten the condenser refocusing clamp before moving the condenser. This will make it easier to restore the condenser to the original position.

12 End the observation.

1. Turn off the dia illumination by pressing the dia illumination lamp ON/OFF switch on the left side of the microscope.
2. Turn off the microscope by pressing the "OFF" side of the POWER switch on the back of the microscope.
3. Turn off the power supply by pressing the "O" side of the POWER switch on the back of the power supply.

If placing a cover on the microscope, wait until the lamp has cooled sufficiently.

2.3 Phase Contrast (Ph) Microscopy

Phase contrast (Ph) microscopy workflow

Outline: Place a phase contrast objective and a condenser cassette that have the same Ph code into the optical path. Center the position of the condenser annular diaphragm in the condenser cassette so that it is aligned with the phase plate ring in the objective.

1 Adjust the focus onto the specimen with BF microscopy. → Page 39



2 Set up for phase contrast microscopy. → Page 39



3 Center the condenser annular diaphragm. → Page 40



4 Observe the specimen. → Page 40



5 Change the objective. → Page 41



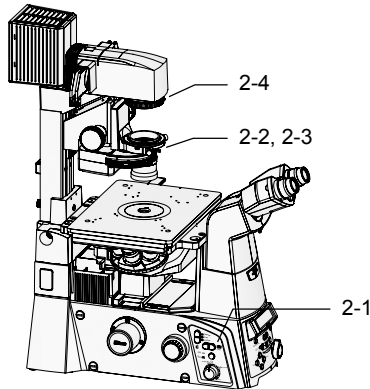
6 Change the specimen. → Page 41



7 End the observation. → Page 42

1 Adjust the focus onto the specimen with BF microscopy.

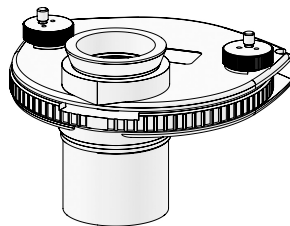
For the BF microscopy procedure, refer to Section 2.2 "Bright-Field (BF) Microscopy."

2 Set up for phase contrast microscopy.

1. **Move the phase contrast objective into the optical path by pressing the Obj. switch on the left operation panel.**
Check the Ph code of the objective.
2. **Rotate the condenser turret to the position for the Ph code of the objective.**
3. **Fully open the aperture diaphragm by moving the aperture diaphragm open/close lever on the condenser clockwise to the limit.**

If the aperture diaphragm is not fully open, the optical path of the annular diaphragm will overlap with the aperture diaphragm, and the phase contrast effect cannot be achieved.
Be sure to fully open the aperture diaphragm when performing phase contrast microscopy.

4. **Fully open the aperture diaphragm by rotating the aperture diaphragm knob on the dia pillar illuminator clockwise to the limit.**

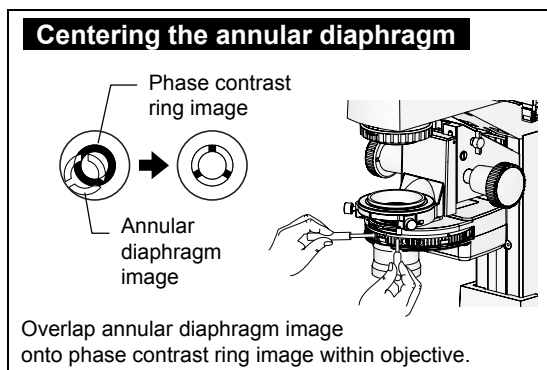
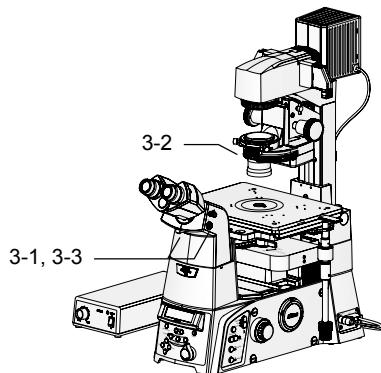
When using the ELWD-S condenser

ELWD-S Condenser

The aperture diaphragm of the ELWD-S condenser is used only for bright-field microscopy. It does not need to be fully opened in step 3, as it has no effect on the optical path for phase contrast.

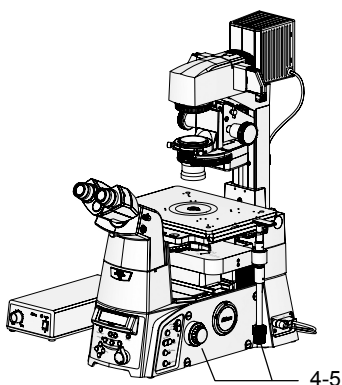
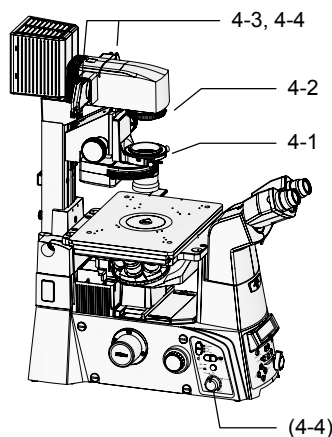
The ELWD-S condenser is designed so that all annular diaphragms become centered when the annular diaphragm is centered at the "PhL" position. Move the "PhL" objective into the optical path, rotate the condenser turret to the "PhL" position, and proceed to the next step.

3 Center the condenser annular diaphragm.



1. Move the Bertrand lens into the optical path by moving the Bertrand lens in/out lever to position "B". Adjust the focus onto the annular diaphragm image by rotating the Bertrand lens focusing knob on the right side of the eyepiece tube.
2. Using the provided hex screwdriver, rotate the two annular diaphragm centering screws on the condenser cassette, and adjust the position of the annular diaphragm image so that it overlaps with the phase contrast ring image within the objective.
3. Move the Bertrand lens in/out lever back to position "O".

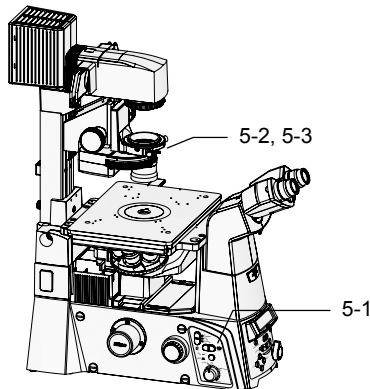
4 Observe the specimen.



1. Check that the aperture diaphragm of the condenser is fully open.
2. Adjust the size of the field diaphragm image to closely match the size of the field of view, by rotating the field diaphragm knob on the dia pillar illuminator.
3. Move the NCB11 filter on the dia pillar illuminator out of the optical path, and move the GIF filter into the optical path.
The GIF filter improves the contrast for phase contrast microscopy.
4. Adjust the brightness for the field of view by moving the ND filters on the dia pillar illuminator in and out of the optical path.

If color reproducibility is not required, brightness adjustment can be performed by changing the lamp voltage with the brightness control knob on the left side of the microscope.

5. Move the stage to bring the observation target into the center of the field of view. Adjust the focus by rotating the focus knobs.

5 Change the objective.

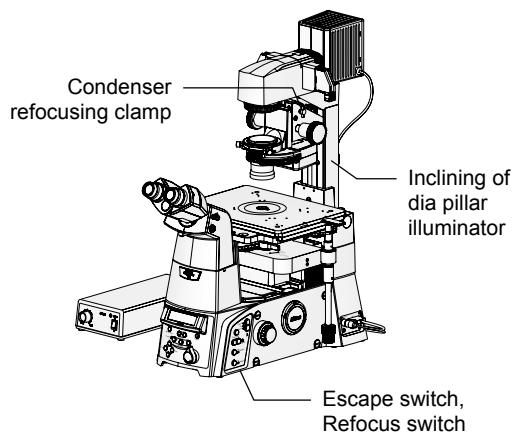
1. **Move a phase contrast objective with the desired magnification into the optical path by pressing the Obj. switch.**

Check the Ph code of the objective.

2. **Rotate the condenser turret to the position for the Ph code of the objective.**
3. **Center the annular diaphragm that is now in the optical path.**

For the centering procedure, refer to step 3 on page 40.

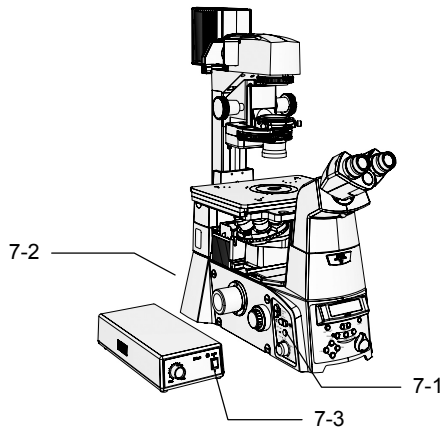
- When attaching phase contrast cassettes to the system condenser, you will need to center all phase contrast cassettes.
- When using the ELWD-S condenser, all annular diaphragms can be simultaneously by centering the annular diaphragm at the "PhL" position.

6 Change the specimen.

Use the following functions as necessary.

- **Inclining of dia pillar illuminator**
When using the 100W dia pillar illuminator, the entire dia pillar illuminator can be inclined backward by loosening the fixing knob on its back side, so as to secure more working space.
- **Escape switch, Refocus switch**
If there is a need to lower the objective, the objective can be retracted temporarily by pressing the Escape switch on the right operation panel.
To return the objective to approximately the same height, press the Refocus switch without rotating the focus knobs.
- **Condenser refocusing clamp**
If there is a need to move the condenser up and down, tighten the condenser refocusing clamp before moving the condenser. This will make it easier to restore the condenser to the original position.

7 End the observation.



1. Turn off the dia illumination by pressing the dia illumination lamp ON/OFF switch on the left side of the microscope.
2. Turn off the microscope by pressing the "OFF" side of the POWER switch on the back of the microscope.
3. Turn off the power supply by pressing the "O" side of the POWER switch on the back of the power supply.

If placing a cover on the microscope, wait until the lamp has cooled sufficiently.

2.4 External Phase Contrast Microscopy

External phase contrast microscopy is a microscopy method proposed by Nikon to be a new standard function of inverted research microscopes.

Traditionally, phase contrast microscopy required the use of special objectives with a built-in phase ring (See Figure 2-2). The phase ring is coated with a phase film, as well as an ND film (light reduction film) for reducing the amount of zero-order light (direct light) that passes. These films sometimes affect imaging and laser transmission, making the phase contrast objectives difficult to use for other applications (i.e. optical tweezers and total reflection fluorescence microscopy).

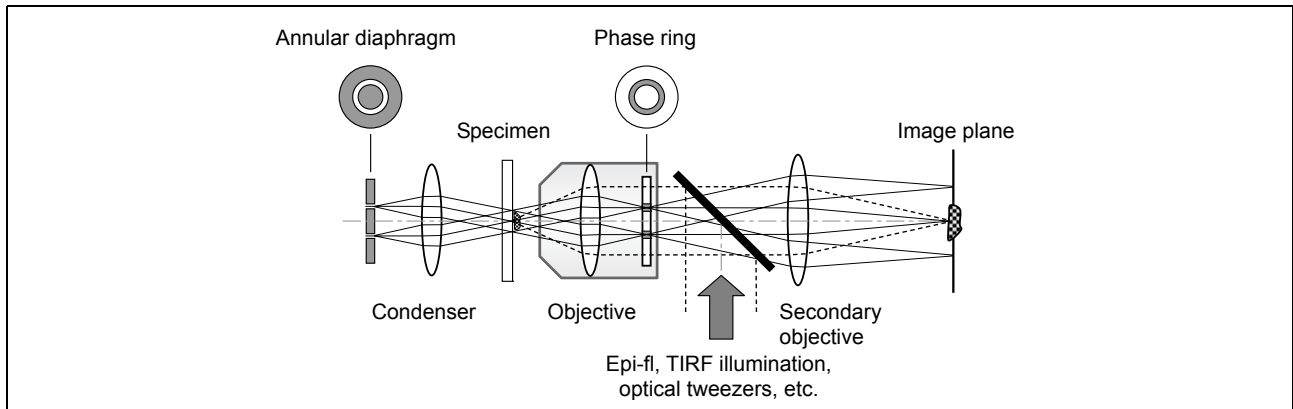


Figure 2-2 Optical path for traditional phase contrast microscopy

An external phase contrast system takes an image on the primary image plane, and refocuses it on the secondary image plane via relay optics. The adoption of such an optical system allows the phase ring to be placed midway in the relay optics, instead of in the objective. In other words, the phase ring can be moved out of the objective (See Figure 2-3). As a result, phase contrast microscopy can now be performed with normal objectives (without a phase ring), and phase contrast objectives are no longer required.

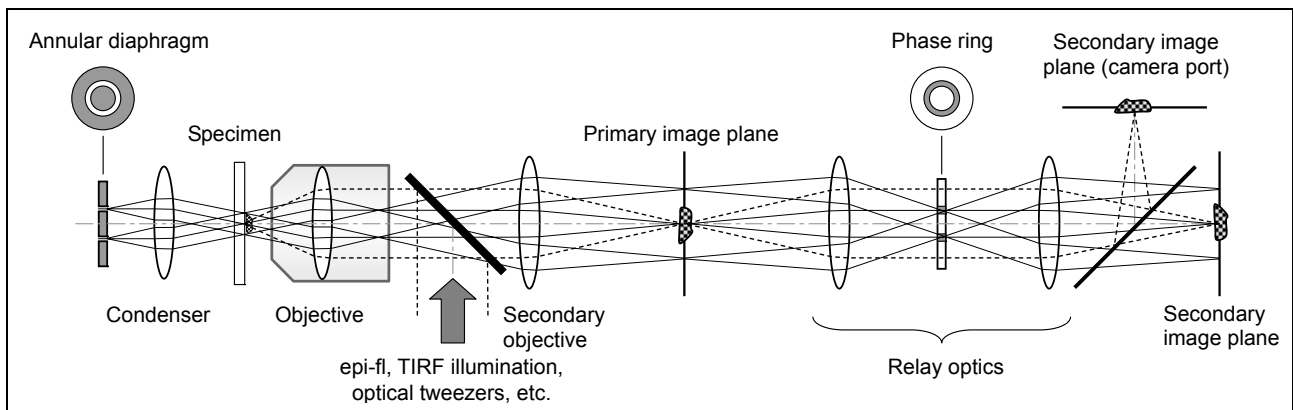


Figure 2-3 Optical path for external phase contrast microscopy

A camera port is also provided on the external phase contrast optics system, enabling photomicroscopy of phase contrast images. For example, a primary image plane camera port (i.e. side port of an inverted microscope) can be used to capture bright fluorescent images unaffected by the phase ring, while by switching the optical path, the camera port on the external phase contrast eyepiece base unit can be used to capture phase contrast images.

The external phase contrast system also supports high-NA TIRF (total internal reflection fluorescence) objectives such as Apo TIRF 60x H/1.49 and Apo TIRF 100x H/1.49, allowing TIRF objectives to be fully utilized for applications that require bright fluorescence images (i.e. monomolecular fluorescence microscopy), while also allowing morphological observations to be performed without changing the objective.

Selecting objectives and phase plates

To perform external phase contrast microscopy, you will need to use the TI-T-BPH External Phase Contrast Eyepiece Base Unit.

You will also need to select a phase plate that is suitable for the objective being used, and attach it to the eyepiece base unit. Refer to the following table to select an objective and an appropriate phase plate.

Up to three phase contrast plates (A, B, and C) can be attached to the TI-T-BPH External Phase Contrast Eyepiece Base Unit.

	Condenser phase contrast code (Supported condenser lens)	Objective	External phase contrast ring
1	Ph3 (LWD, CLWD)	P Apo 60x WI (NA1.2)	60x/Ph3
2	Ph3 (LWD, CLWD)	P Apo VC 60x WI (NA1.2)	60x/Ph3
3	Ph3 (LWD, CLWD)	P Apo VC 60x H (NA1.4)	60x/Ph3
4	Ph4 (CLWD)	Apo TIRF 60x H (NA1.49)	60x/Ph4
5	Ph4 (CLWD)	P Apo TIRF 60x H (NA1.45)	60x/Ph4
6	Ph3 (LWD, CLWD)	P Apo VC 100x H (NA1.4)	100x/Ph3
7	Ph4 (CLWD)	Apo TIRF 100x H (NA1.49)	100x/Ph4

External phase contrast microscopy workflow

Outline: Place the objective (refer to the table above), the condenser lens, and the condenser cassette into the optical path. Center the positions of the eyepiece base unit (TI-T-BPH) and the ring in the condenser cassette.

1 Adjust the focus onto the specimen with BF microscopy. ➔ Page 45

2 Center the external phase contrast ring. ➔ Page 45

3 Center the condenser annular diaphragm. ➔ Page 46

4 Observe the specimen. ➔ Page 46

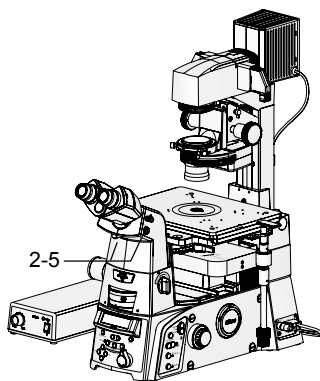
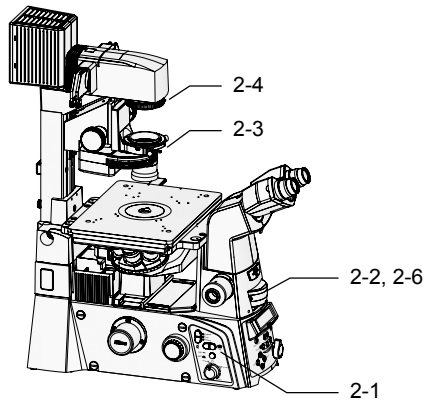
5 Change the objective. ➔ Page 47

6 Change the specimen. ➔ Page 47

7 End the observation. ➔ Page 48

1 Adjust the focus onto the specimen with BF microscopy.

For the BF microscopy procedure, refer to Section 2.2 "Bright-Field (BF) Microscopy".

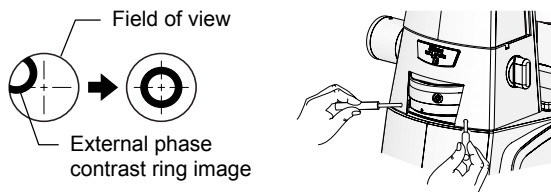
2 Center the external phase contrast ring.

1. **Move an external phase contrast objective into the optical path by pressing the Obj. switch on the left operation panel.**
Check the Ph code of the objective.
2. **Move an external phase contrast ring suitable for the objective into the optical path, by rotating the turret on the eyepiece base unit.**
Set to position "A", "B", or "C". Position "O" is empty.
3. **Rotate the condenser turret to position "A", for bright-field microscopy. Fully open the aperture diaphragm by moving the aperture diaphragm open/close lever on the condenser to the limit.**

If the aperture diaphragm is not fully open, the optical path of the annular diaphragm will overlap with the aperture diaphragm, and the phase contrast effect cannot be achieved.

4. **Fully open the aperture diaphragm by rotating the aperture diaphragm knob on the dia pillar illuminator clockwise to the limit.**
5. **Move the Bertrand lens into the optical path by moving the Bertrand lens in/out lever on the front of the eyepiece tube to position "B". Adjust the focus onto the external phase contrast ring placed into the optical path by the eyepiece base unit, by rotating the Bertrand lens focusing knob.**
6. **Insert the provided hex screwdriver into the centering screw hole on the front of the eyepiece base unit, and adjust the external phase contrast ring into the center of the field of view.**

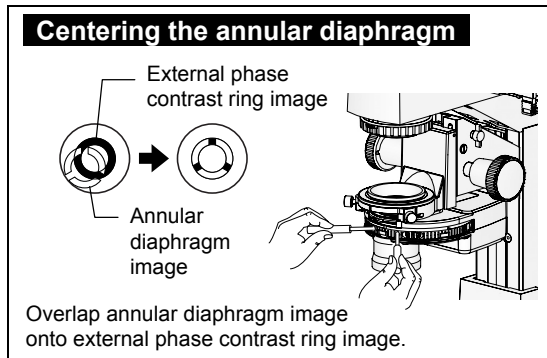
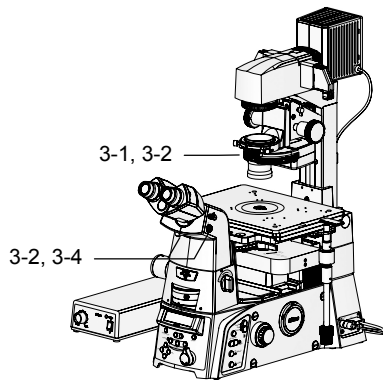
After adjusting, tighten the two centering clamp screws on the back of the eyepiece base unit.

Centering the external phase contrast ring

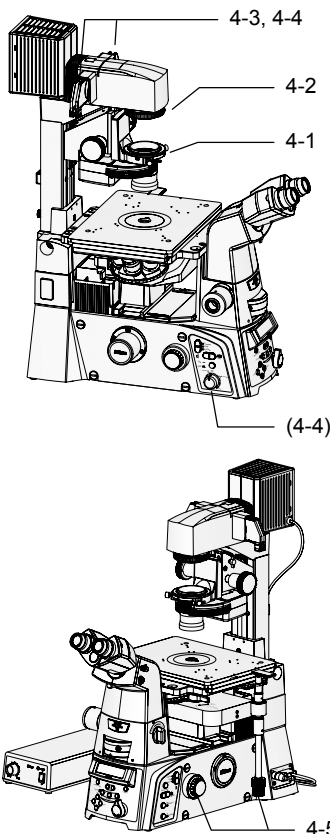
Move external phase contrast ring image into center of field of view.

When centering with the eyepiece base unit turret, the whole turret will be moved, unlike when adjusting the condenser turret. Adjustment is not made independently for each phase plate.

If adjustment with the above procedure is difficult, attach the provided target (adjustment tool) onto the nosepiece. Using the bright-field illumination, adjust the position of the external phase contrast ring so that its image becomes concentric with the target.

3 Center the condenser annular diaphragm.

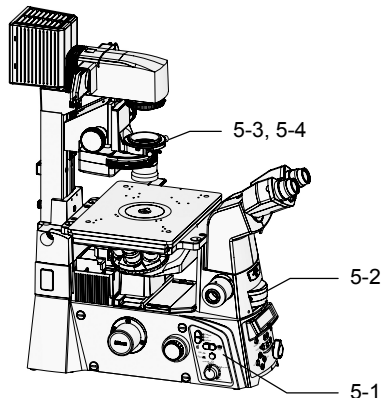
1. Rotate the condenser turret to the position for the Ph code of the external phase contrast ring in the optical path.
2. With the Bertrand lens adjusted in step 2 in the optical path, use the provided hex screwdriver to adjust the two annular diaphragm centering screws on the condenser cassette so that the annular diaphragm image overlaps with the phase contrast ring image.
3. Check that the two images are concentric.
4. Move the Bertrand lens out of the optical path by moving the Bertrand lens in/out lever back to position "O".

4 Observe the specimen.

1. Fully open the aperture diaphragm of the condenser.
2. Adjust the size of the field diaphragm image to closely match the size of the field of view, by rotating the field diaphragm knob on the dia pillar illuminator.
3. Move the NCB11 filter on the dia pillar illuminator out of the optical path, and move the GIF filter into the optical path.
The GIF filter improves the contrast for phase contrast microscopy.
4. Adjust the brightness for the field of view by moving the ND filters on the dia pillar illuminator in and out of the optical path.

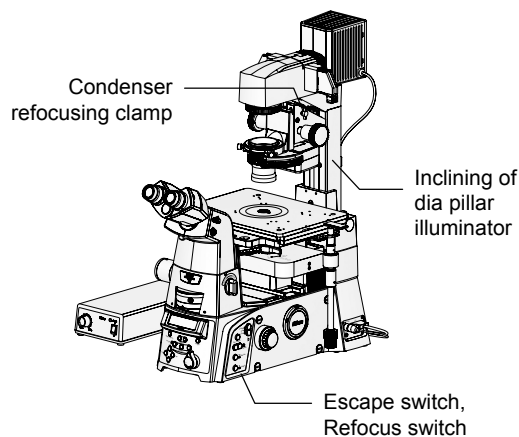
If color reproducibility is not required, brightness adjustment can be performed by changing the lamp voltage with the brightness control knob on the left side of the microscope.

5. Move the stage to bring the observation target into the center of the field of view. Adjust the focus by rotating the focus knobs.

5 Change the objective.

1. Move another external phase contrast objective into the optical path by pressing the Obj. switch on the left operation panel.
2. Rotate the eyepiece base unit turret to the position for the external phase contrast ring that is suitable for the objective in the optical path.
3. Rotate the condenser turret to the position for the Ph code of the objective.
4. Center the annular diaphragm of the condenser.

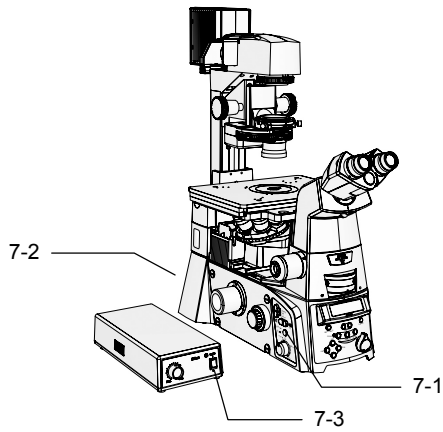
For the centering procedure, refer to step 3 on page 46.

6 Change the specimen.

Use the following functions as necessary.

- **Inclining of dia pillar illuminator**
When using the 100W dia pillar illuminator, the entire dia pillar illuminator can be inclined backward by loosening the fixing knob on its back side, so as to secure more working space.
- **Escape switch, Refocus switch**
If there is a need to lower the objective, the objective can be retracted temporarily by pressing the Escape switch on the right operation panel.
To return the objective to approximately the same height, press the Refocus switch without rotating the focus knobs.
- **Condenser refocusing clamp**
If there is a need to move the condenser up and down, tighten the condenser refocusing clamp before moving the condenser. This will make it easier to restore the condenser to the original position.

7 End the observation.



1. Turn off the dia illumination by pressing the dia illumination lamp ON/OFF switch on the left side of the microscope.
2. Turn off the microscope by pressing the "OFF" side of the POWER switch on the back of the microscope.
3. Turn off the power supply by pressing the "O" side of the POWER switch on the back of the power supply.

If placing a cover on the microscope, wait until the lamp has cooled sufficiently.

2.5 In-focus Observation with PFS

In-focus observation is an observation method implemented by combining a Ti-E or Ti-E/B microscope with a PFS Motorized Nosepiece. The system detects the boundary surface between the cover glass and the aqueous solution of the specimen (for water immersion or oil immersion objectives) ^(NOTE 1) or between the cover glass and air (for dry objectives) ^(NOTE 1), and maintains the focus by controlling the focusing mechanism to track the vertical movement of the boundary surface. This method achieves a constant focal distance by compensating for minor focus shifts that may result over time or by stage movements. In this manual, this method will be referred to as in-focus observation (or PFS observation ^(NOTE 2)).

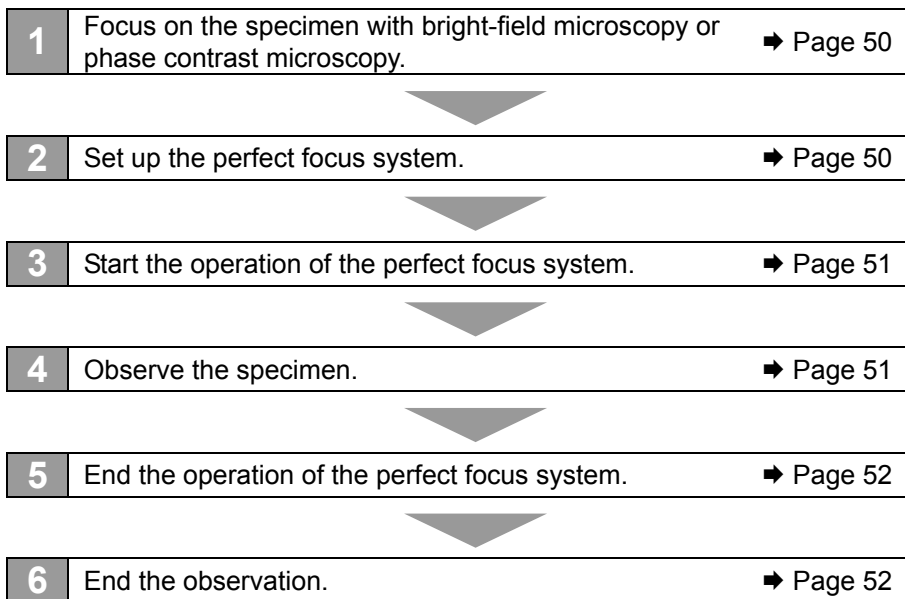
NOTE 1: The boundary surface is also referred to as an "interface".

NOTE 2: PFS = Perfect Focus System

In-focus observation workflow

Outline: Perform bright-field microscopy or phase contrast microscopy with the TI-ND6-PFS PFS Motorized Nosepiece.

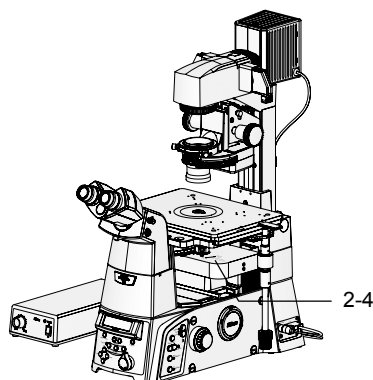
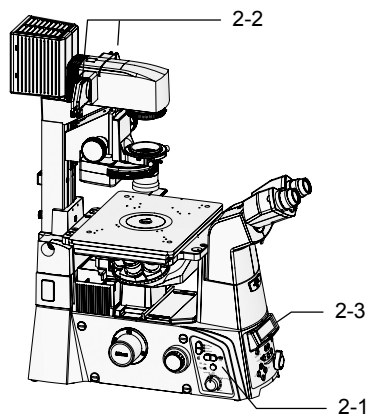
* To perform in-focus observation, you must register the objective information on the microscope. For registration details, refer to Chapter 4, "Assembly." This section describes the microscopy procedures under the assumption that the objective information has already been registered.



1 Focus on the specimen with bright-field microscopy or phase contrast microscopy.

Set up for bright-field microscopy or phase contrast microscopy, as described in Section 2.2, “Bright-Field (BF) Microscopy,” Section 2.3, “Phase Contrast (Ph) Microscopy,” or Section 2.4, “External Phase Contrast Microscopy.”

2 Set up the perfect focus system.



1. Move a PFS objective with the desired magnification into the optical path by pressing the Obj. switch on the left operation panel.
2. Attach an IR filter (infrared filter) to the filter sliders on the pillar illuminator, and move it into the optical path.

PFS uses near-infrared light for focus management. Be sure to place the IR filter into the optical path to minimize the effect of the heat rays (infrared light) emitted by the illumination.

3. Display the PFS information on the status display panel by pressing the DISPLAY switch on the front operation panel.

At this point, “PFS: Out” will be displayed.

■ Display example for PFS information

E100 Coarse	10x/0.25	PFS:Out
-------------	----------	---------

4. Move the dichroic mirror into the optical path by moving the DICHROIC MIRROR - IN/OUT lever on the top of the PFS Motorized Nosepiece to the “IN” position.

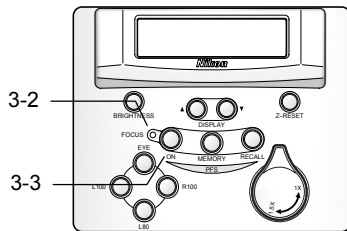
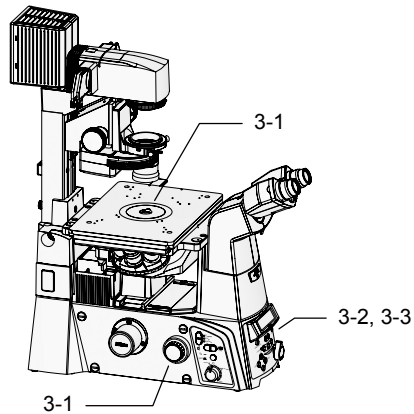
The PFS information display will change to “PFS: Off”.

■ Display example for PFS information

E100 Coarse	10x/0.25	PFS:Off
-------------	----------	---------

If “PFS: ER1” is displayed, the objective has not been configured properly. Check and register the objective. Refer to the list of supported objectives on page 127, and to Chapter 4, “Assembly”.

3 Start the operation of the perfect focus system.



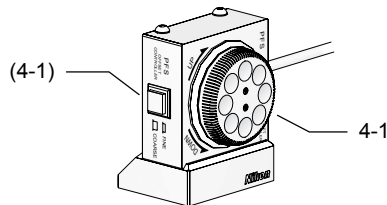
1. Move the stage to bring the observation target into the center of the field of view. Adjust the focus onto the specimen by rotating the focus knobs.
2. Check that the FOCUS indicator on the front operation panel is lit.
If not, try moving the focus slightly.
3. Start the PFS function by pressing the PFS-ON switch on the front operation panel.

The PFS-ON switch will be lit, and the PFS information will change to "PFS: On".

■ PFS control started

E100 Coarse	10x/0.25	PFS:On
-------------	----------	--------

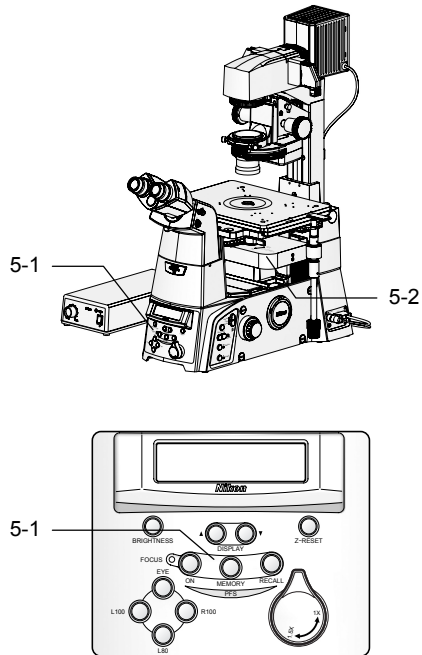
4 Observe the specimen.



1. The observation surface can be moved up and down without losing the focus, by rotating the offset dial on the PFS Offset Controller.

The offset traveling distance for the dial can be switched between "Coarse" and "Fine" with the FINE/COARSE switch on the side of the PFS Offset Controller.

4x and 10x objectives can be operated in FINE mode only. The FINE/COARSE selector switch will be disabled for these objectives.

5 End the operation of the perfect focus system.

1. Turn off the PFS function by pressing the illuminated PFS-ON switch.

The PFS information display will change to "PFS: Off".

■ PFS control stopped

E100 Coarse	10x/0.25	PFS:Off
-------------	----------	---------

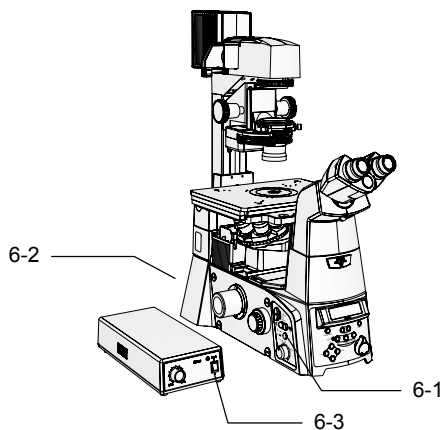
2. Move the dichroic mirror out of the optical path by moving the DICHROIC MIRROR - IN/OUT lever on the top of the PFS Motorized Nosepiece to the "OUT" position.

The PFS information display will change to "PFS: Out".

■ Dichroic mirror: Out

E100 Coarse	10x/0.25	PFS:Out
-------------	----------	---------

Be sure to stop the PFS function before changing the specimen or ending the observation.

6 End the observation.

1. Turn off the dia illumination by pressing the dia illumination lamp ON/OFF switch on the left side of the microscope.
2. Turn off the microscope by pressing the "OFF" side of the POWER switch on the back of the microscope.
3. Turn off the power supply by pressing the "O" side of the POWER switch on the back of the power supply.

If placing a cover on the microscope, wait until the lamp has cooled sufficiently.

3

Operation



Warning

- Before using the product, thoroughly read the “Safety Precautions” at the beginning of this manual, and heed all warnings and cautions written therein.
- To use other equipment such as epi-fl attachment or differential interference contrast attachment, refer to the respective manuals and heed all warnings and cautions written therein.



Caution

When using the PFS Motorized Nosepiece, use the “Ti Control” setup software for Ti series to register the objective information from a PC. PFS Motorized Nosepiece will not function properly unless the objective information has been registered correctly. For details on using “Ti Control”, refer to the “Ti Control” instruction manual.

This chapter describes the operation methods for each part of the product.

- For the name and position of each part, refer to Chapter 1, “Part Names.”
- For the microscopy procedure, refer to Chapter 2, “Microscopy.”
- If the microscope has not been assembled yet, first refer to Chapter 4, “Assembly.”
- If your microscope system has the epi-fl attachment or the differential interference contrast attachment, refer to the respective instruction manuals.
- If your microscope system is equipped with the TI-HUBC/A Hub Controller A, refer to the instruction manual provided with the hub controller.

3.1 Power On/Off

3.1.1 Power On

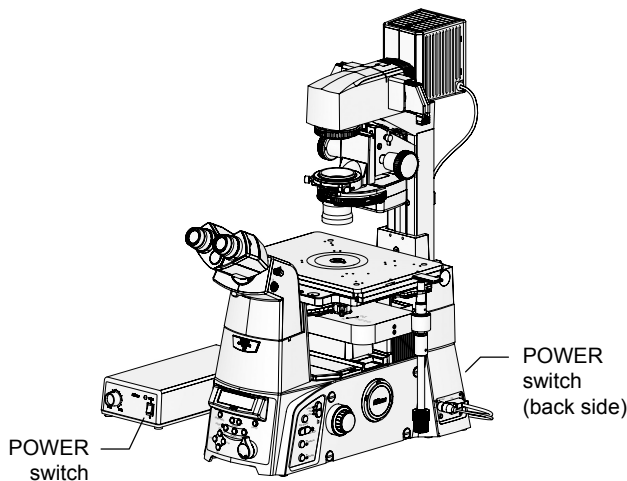


Figure 3-1 Power switch locations

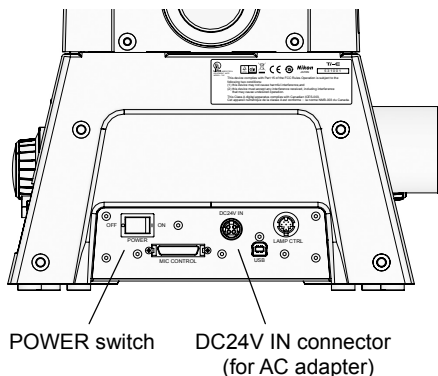


Figure 3-2 Ti-E (rear view)

Turn on the dia illumination power supply and the microscope, as described below.

1. **Check that the power supply and the microscope are connected correctly.**

For details on the connection, refer to Chapter 4, “Assembly.”

2. **Check the setting of the EXTERNAL switch (or the CTRL switch) on the back of the power supply.**

To use the brightness control knob on the microscope, set the switch to ON. To use the brightness control knob on the power supply, set the switch to OFF.

For details, refer to Section 3.2.2, “Power Supply Setting.”

3. **Turn on the power supply by pressing the “I” side of the POWER switch on the front of the power supply.**

When the power is ON, the POWER indicator will be lit.

* On TE-PS30W and TE-PSE30, the POWER switch has a built-in power indicator.

4. **Turn on the microscope by pressing the “ON” side of the POWER switch on the back of the microscope.**

Power to the Ti-E or Ti-E/B microscope is supplied via the AC adapter. Check the connection of the AC adapter before turning on the power.

See Chapter 4, “Assembly.”

When the power is turned on, indicator lamps on the front and the side of the microscope will be lit, and the system status is displayed on the status display panel on the front.

3.1.2 Power Off

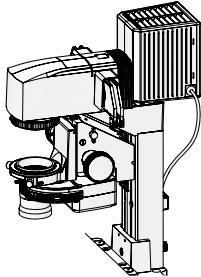
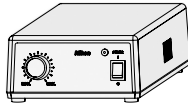
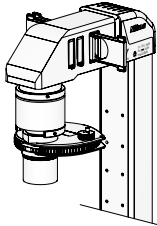
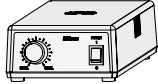
To turn the microscope off, first turn off the microscope, and then turn off the dia illumination power supply.

The microscope can be turned off by pressing the “OFF” side of the POWER switch on the back of the microscope body. The power supply can be turned off by pressing the “O” side of the POWER switch on the front of the power supply.

3.2 Dia Illumination Operation

3.2.1 Combination of Lamp, Dia Pillar Illuminator, and Power Supply

The combination of the dia pillar illuminator and the power supply will differ depending on the rating of the lamp used (12V 100W or 6V 30W). Refer to the following table for the correct combination of lamp, dia pillar illuminator, and power supply. Do not use the devices in any other combination.

Lamp rating	Dia pillar illuminator	Power supply	
12V 100W halogen lamp (OSRAM HLX 64623 or PHILIPS 77241)	TI-DH Dia Pillar Illuminator 100W 	TI-PS100W Power Supply (for 100-240V) 	
6V 100W halogen lamp (PHILIPS 5761)	TI-DS Dia Pillar Illuminator 30W 	TE-PS30W Power Supply A (for 100-120V)	TE-PSE30 Power Supply A (for 230V)
		 * Both power supply units have the same appearance.	

3.2.2 Power Supply Setting

EXTERNAL switch/CTRL switch
ON : Use the brightness control knob on the microscope.
OFF : Use the brightness control knob on the power supply device.

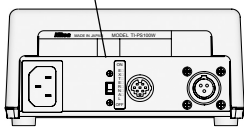


Figure 3-3 Power supply (rear view)

The EXTERNAL switch (or CTRL switch) on the back of the power supply can be set to allow switching dia illumination lamp on/off and controlling brightness from the left operation panel of the microscope.

If the EXTERNAL/CTRL switch is set to ON, the operation panel on the microscope will be enabled; if the switch is set to OFF, the brightness control knob on the power supply will be enabled. Only one or the other of the brightness control knobs can be enabled at a time.

The two knobs are not calibrated. A particular setting on one knob may result in a different brightness than for the same setting on the other knob.

3.2.3 Dia Illumination Lamp Operation

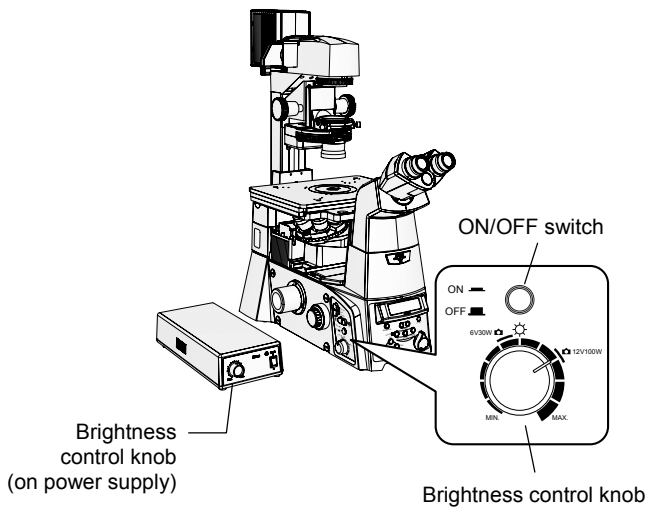


Figure 3-4 Dia illumination lamp operation

Switching dia illumination lamp ON/OFF

When the EXTERNAL/CTRL switch on the power supply is set to ON, the dia illumination can be turned on/off with the dia illumination ON/OFF switch on the left operation panel of the microscope.

Push the switch in to turn on the dia illumination. Push the switch again to turn off the dia illumination.

Adjusting brightness of dia illumination lamp

Two brightness control knobs are provided for the dia illumination: one on the left side of the microscope, and the other on the front of the power supply.

When the brightness control knob is rotated, the lamp voltage changes, changing the brightness and the color of the lamp. When the voltage is increased, the light becomes bright and bluish. When the voltage is decreased, the light becomes dark and reddish.

White light

When accurate color reproduction is critical, set the brightness adjustment knob to the “6V30W” or “12V100W” position depending on the lamp used, then move the NCB11 filter into the optical path. This setting will provide the whitest light. To adjust the brightness, adjust the ND filters on the dia pillar illuminator.

3.2.4 Brightness Adjustment with ND Filters

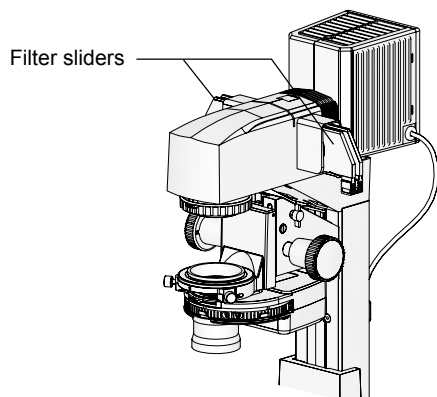


Figure 3-5 Brightness adjustment with ND filters

Filters for brightness adjustment are referred to as “ND filters” (ND: Neutral Density).

Filters with higher ratings have lower transmittance, and produces darker images. These filters are useful for adjusting the brightness when color reproducibility is critical (i.e. for photomicroscopy), as they do not affect the color of the light.

Use the ND filters by attaching them to the filter sliders on the dia pillar illuminator.

- **ND2:** Reduces the light intensity to 1/2. (50% transmittance)
- **ND4:** Reduces the light intensity to 1/4. (25 % transmittance)
- **ND8:** Reduces the light intensity to 1/8. (12.5 % transmittance)
- **ND16:** Reduces the light intensity to 1/16. (6.3 % transmittance)

3.3 Controls on the Microscope Body

Ti-E and Ti-E/B microscope bodies have operation panels on the front, left, and right for operation of various motorized parts.

3.3.1 Front Operation Panel

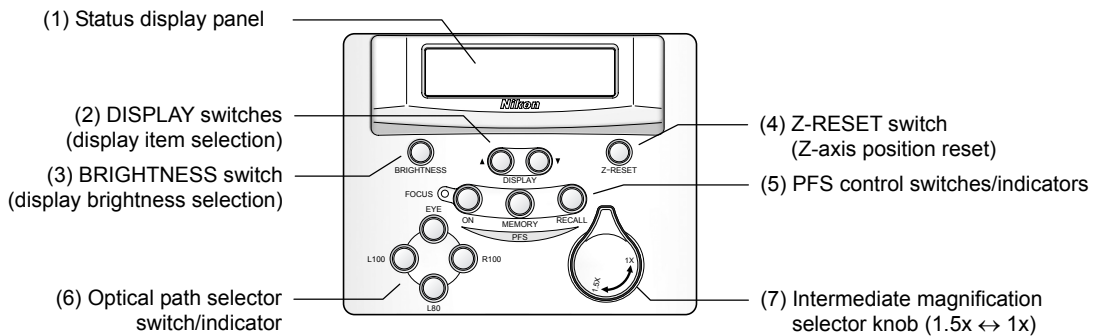


Figure 3-6 Front operation panel

(1) Status display panel

The microscope status appears here. Multiple display patterns are provided. Select the pattern that best suits your need. When the microscope is turned on, the initial pattern will be displayed. (See page 58.)

(2) DISPLAY switches (display item selection)

The up/down arrow switches change the display content of the status display panel. Multiple display patterns are provided. (See page 58.)

(3) BRIGHTNESS switch (display brightness selection)

This switch changes the illumination of the status display panel and LEDs on the body between bright, dim, and off. Use this switch to darken the room for epi-fl microscopy or so on.

When the switch is pressed, the status will cycle in the following order: [Panel ON, LED ON] → [Panel dim, LED OFF] → [Panel OFF, LED OFF].

(4) Z-RESET switch (Z-axis position reset)

Press this switch to reset the Z-axis position on the status display panel to zero. The Z-axis position display will be increased when the nosepiece is elevated, and decreased when the nosepiece is lowered. By resetting the Z-axis position display after setting the focus, you will be to use the set position as a reference point. For details, refer to Section 3.10, "Focusing Mechanism Operation."

(5) PFS control switches and indicator

These controls are used for in-focus observation with the PFS (Perfect Focus System). For details, refer to Section 3.14, "PFS Operation."

FOCUS indicator: The indicator shows the in-focus status. When the objective is placed in the focus range, the indicator blinks. When the PFS focuses on the reference position, the indicator turns on.

ON switch: This switch turns on/off the in-focus (PFS) function. The switch body is lit when the PFS function is ON.

MEMORY switch: Press this switch to register the distance (offset) from the reference position to a given focal position. When an offset is registered, the switch body is lit.

RECALL switch: Press this switch to restore the offset.

(6) Optical path selector switch/indicator

This switch changes the output port for the image. The switch for the selected port will be lit. For details, refer to Section 3.4, "Optical Path Selection."

(7) Intermediate magnification selector knob (1.5x ↔ 1x)

Rotate the knob to change the magnification of the microscope body between 1x (1x objective magnification) and 1.5x (1.5x objective magnification). The setting of this knob is applied for all output ports.

Display pattern selection for the status display panel

The display content of the status display panel can be switched between the following three display patterns by pressing the DISPLAY switch. The display content differs for each display pattern. Select the pattern that best suits your need.

Pattern	Display contents	Display example
A	Upper: Z-axis position (unit: μm) Lower: Output port, Focus knob resolution	Z: 124.375 μm E100 Coarse
B	Upper: Objective status (1) Lower: Output port, Focus knob resolution, PFS status	P Fluor 100x/1.30 E100 Coarse PFS:Off
C	Upper: Objective status (2), Z-axis position (unit: μm) Lower: Output port, Focus knob resolution, PFS status	PF100x Z: 124.375 μm E100 Coarse PFS:Off

* Additional display patterns will become available when using TI-HUBC/A Hub Controller A. For details, refer to the instruction manual provided with TI-HUBC/A Hub Controller A.

Display content details

Objective status (1) [name, magnification, NA]	(Blank)	:Achromat
	Apo TIRF	:Apo TIRF
	Plan	:Plan
	P Apo	:Plan Apo
	P Apo TIRF	:Plan Apo TIRF
	P Apo UC	:Plan Apo VC
	P Fluor	:Plan Fluor
	Plan UW	:Plan UW
	S Fluor	:S Fluor
	S P Fluor	:S P Fluor
	HMC	:HMC
Other	:Other information	
Objective status (2) [name, magnification]	(Blank)	:Achromat
	A	:Apo TIRF
	P	:Plan
	PA	:Plan Apo (TIRF/VC)
	PT	:Plan Apo TIRF
	PV	:Plan Apo VC
	PF	:Plan Fluor
	P	:Plan UW
	SF	:S Fluor
	SP	:S P Fluor
	HM	:HMC
OT	:Other information	
Output port	E100	Observation port 100%
	L80	Left port 80%, observation port 20%
	L100	Left port 100%
	R80	Right port 80%, observation port 20%
	R100	Right port 100%
	B100	Bottom port 100%
Z-axis position	Z: 0000.000 μm	+ direction: Direction of upward objective movement
	Z: -0000.000 μm	- direction: Direction of downward objective movement
Focus knob resolution	Coarse	Coarse
	Fine	Fine
	ExFine	Extra fine
PFS status	PFS:On	PFS function ON
	PFS:Off	PFS function OFF
	PFS:Out	Dichroic mirror not in optical path
	PFS:DIS	Out of PFS function range
	PFS:ERn	Error (See Chapter 5, "Troubleshooting")

3.3.2 Left Operation Panel

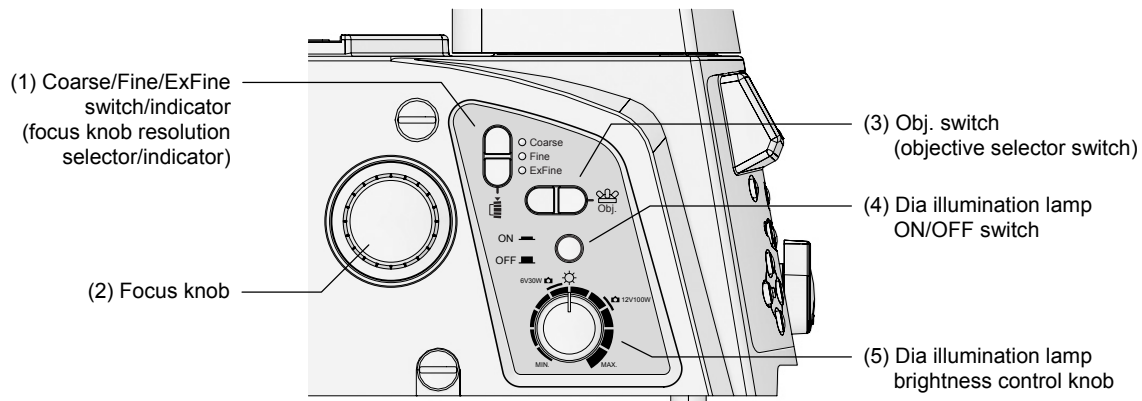


Figure 3-7 Left operation panel

(1) Coarse/Fine/ExFine switch/indicator (focus knob resolution selector/indicator)

Selects the resolution for the vertical movement of the nosepiece for when the focus knobs on the sides are rotated. Press the upper switch to cycle in the following order: ExFine (extra fine) → Fine → Coarse. Press the lower switch to cycle in the opposite order.

The selected resolution will be indicated by the indicator on the switch, as well as on the status display panel.

For details, refer to Section 3.10, “Focusing Mechanism Operation.”

(2) Focus knob

This knob moves the nosepiece vertically for focus adjustment. Viewing the microscope from its left side, a clockwise rotation elevates the nosepiece, while a counterclockwise rotation lowers the nosepiece.

(3) Obj. switch (objective selector)

Changes the objective in the optical path by rotating the PFS Motorized Nosepiece or the Motorized Sextuple DIC Nosepiece. Press the front switch for a clockwise rotation, or the rear switch for a counterclockwise rotation.

TI-HUBC/A Hub Controller A is required to use the TI-ND6-E Motorized Sextuple DIC Nosepiece. TI-N6 Sextuple Nosepiece and TI-ND6 Sextuple Nosepiece are manually operated, and cannot be controlled by the Obj. switch.

(4) Dia illumination lamp ON/OFF switch

Turns the dia illumination on/off. Push the switch in to turn on the dia illumination. Push the switch again to turn off the dia illumination.

For details, refer to Section 3.2.3, “Dia Illumination Operation.”

(5) Dia illumination lamp brightness control knob

Adjusts the brightness of the dia illumination by changing the voltage for the lamp. When the voltage is increased, the light becomes bright and bluish. When the voltage is decreased, the light becomes dark and reddish.

When accurate color reproduction is critical, set the brightness adjustment knob to the “6V30W” or “12V100W” position depending on the lamp used, then move the NCB11 filter into the optical path.

For details, refer to Section 3.2.3, “Dia Illumination Operation.”

3.3.3 Right Operation Panel

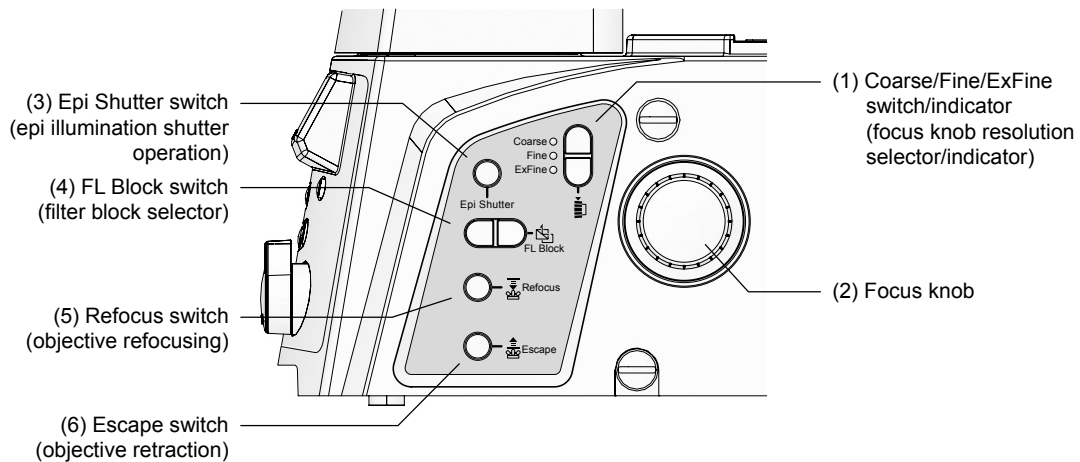


Figure 3-8 Right operation panel

(1) Coarse/Fine/ExFine switch/indicator (focus knob resolution selector/indicator)

Selects the resolution for the vertical movement of the nosepiece for when the focus knobs on the sides are rotated. Press the upper switch to cycle in the following order: ExFine (extra fine) → Fine → Coarse. Press the lower switch to cycle in the opposite order.

The selected resolution will be indicated by the indicator on the switch, as well as on the status display panel.

For details, refer to Section 3.10, “Focusing Mechanism Operation.”

(2) Focus knob

This knob moves the nosepiece vertically for focus adjustment. Viewing the microscope from its right side, a clockwise rotation lowers the nosepiece, while a counterclockwise rotation elevates the nosepiece.

(3) Epi Shutter switch (epi illumination shutter operation)

This switch opens/closes the motorized shutter for the epi illumination.

The Epi Shutter switch becomes enabled when TI-HUBC/A Hub Controller A and a motorized shutter for epi illumination are attached. For details, refer to the instruction manual provided with Hub Controller A.

(4) FL Block switch (filter block selector)

Changes the filter block in the optical path by rotating the motorized filter turret.

The FL Block switch becomes enabled when TI-HUBC/A Hub Controller A and a motorized filter turret are attached. For details, refer to the instruction manual provided with Hub Controller A.

(5) Refocus switch (objective refocusing)

Moves an objective retracted with the Escape switch back to the original position.

For details, refer to Section 3.10, “Focusing Mechanism Operation.”

(6) Escape switch (objective retraction)

Moves the objective to the retracted position (approximately 2 mm below the reference position).

For details, refer to Section 3.10, “Focusing Mechanism Operation.”

3.4 Optical Path Selection

The microscope has several observation ports. Use the optical path selector switches on front operation panel to distribute the optic image to the ports. The switch for the selected port will be lit, and the port name will be displayed on the status display panel.

3.4.1 For Ti-E

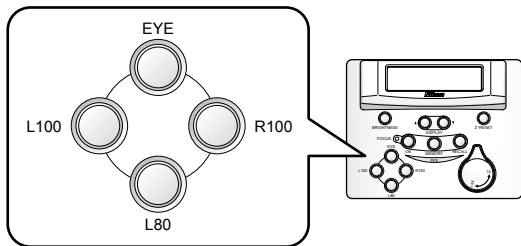


Figure 3-9 Ti-E optical path selector switches

	Switch	Light distribution
(1)	EYE	Eyepiece observation port 100%
(2)	L100	Left side port 100%
(3)	R100	Right side port 100%
(4)	L80	Left side port 80%, eyepiece observation port 20%

* (3) or (4) may be set to R80 (right side port 80%, eyepiece observation port 20%) depending on your purchased configuration.

3.4.2 For Ti-E/B

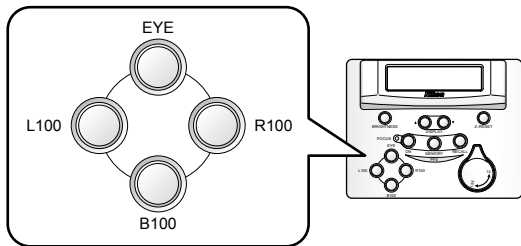
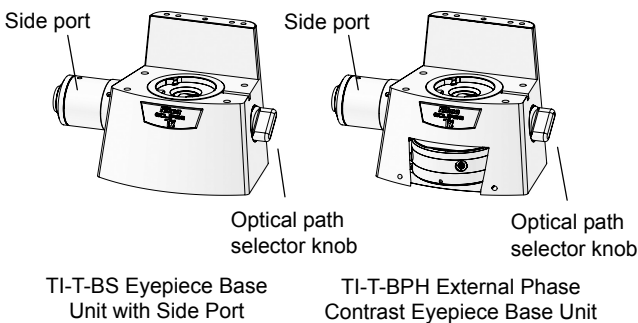


Figure 3-10 Ti-E/B optical path selector switches

	Switch	Light distribution
(1)	EYE	Eyepiece observation port 100%
(2)	L100	Left side port 100%
(3)	R100	Right side port 100%
(4)	B100	Bottom port 100%

* (3) may be set to R80 (right side port 80%, eyepiece observation port 20%) or L80 (left side port 80%, eyepiece observation port 20%), depending on your purchased configuration.

3.4.3 Eyepiece Base Unit Options



TI-T-BS Eyepiece Base Unit with Side Port

TI-T-BPH External Phase Contrast Eyepiece Base Unit

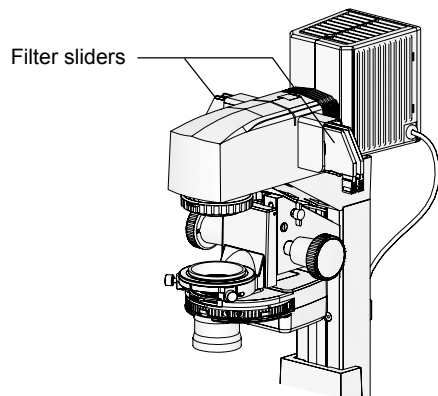
Figure 3-11 Eyepiece base unit side ports

TI-T-BS Eyepiece Base Unit with Side Port and TI-T-BPH External Phase Contrast Eyepiece Base Unit have a side port equipped with a C-mount adapter.

When using these eyepiece base units, you will be able to use both the eyepiece observation port and the base unit side port. To do so, select the eyepiece observation port with the optical selector switches.

To switch between the eyepiece observation port and the side port, use the optical path selector knob on the right side of the eyepiece base unit.

3.5 Filter Operation



Filter sliders can be attached to the pillar illuminator (up to four on the 100W model, and three on the 30W model).

Use the necessary filters by attaching them to the filter sliders.

The following filters are available:

Figure 3-12 Filter sliders (Dia Pillar Illuminator 100W)

Table: List of filters

Filter name	Description
ND2	Adjusts the brightness for normal microscopy or photomicroscopy (ND: Neutral Density). Reduces the light intensity to 1/2. (Transmittance: Approx. 50%)
ND4	Adjusts the brightness for normal microscopy or photomicroscopy (ND: Neutral Density). Reduces the light intensity to 1/4. (Transmittance: Approx. 25%)
ND8	Adjusts the brightness for normal microscopy or photomicroscopy (ND: Neutral Density). Reduces the light intensity to 1/8. (Transmittance: Approx. 12.5%)
ND16	Adjusts the brightness for normal microscopy or photomicroscopy. (ND: Neutral Density) Reduces the light intensity to 1/16. (Transmittance: Approx. 6%)
NCB11	Corrects the color temperature for normal microscopy or filming by daylight type color TV cameras (NCB: Neutral Color Balance). Color reproducibility is optimal when this filter is placed in the optical path and the lamp voltage is matched to the lamp rating. Keep this filter out of the optical path when filming in black and white.
GIF	Green interference filter. Improves the contrast for when observing under a monochrome light or when filming in black and white.
D	Diffusion filter. This filter is made of frosted glass and will diffuse light. Use this filter to equalize the illumination.
HA	Absorbs the heat rays in the illumination (HA: Heat Absorption). This filter reduces the effect of heat on the specimen. While the dia pillar illuminators have a built-in heat insulation filter, it is recommended that this filter be used for specimens that are sensitive to heat.
IR	Infrared filter for PFS (IR: Infra-Red). Use this filter when using the PFS function with dia illumination.

3.6 Field Diaphragm Operation

(TI-DH Dia Pillar Illuminator 100W only)

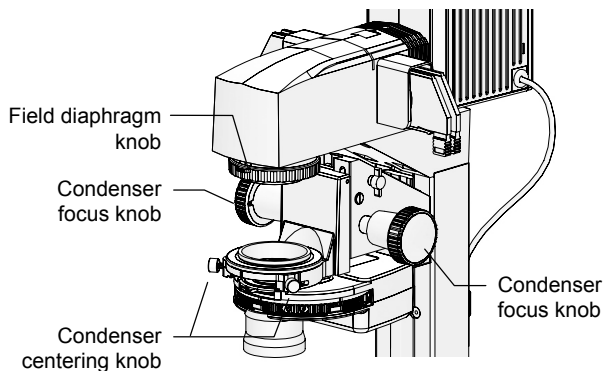


Figure 3-13 Field diaphragm knob

The field diaphragm is used to limit the irradiation area of the lamp to the microscope's field of view.

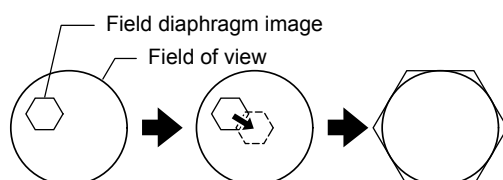
As viewed from the top of the pillar illuminator, a counterclockwise rotation of the field diaphragm knob increases the diameter of the irradiation area, and a clockwise rotation decreases the diameter of the irradiation area.

Usually, the irradiation area is adjusted to a size that circumscribes (or inscribes) the field of view. An unnecessarily large irradiation area will result in stray light and flare, thereby reducing the contrast of the optic image.

Field diaphragm adjustment is particularly important when performing photomicroscopy. Typically, adjusting the irradiation area to be slightly larger than the size of the image sensor (indicated by the capture area frame) will yield favorable results. Avoid making the size of the irradiation area too close to the size of the image sensor, as it may result in vignetting.

The field diaphragm of the TI-DS Dia Pillar Illuminator 30W has a fixed opening size. It cannot be adjusted.

Field diaphragm adjustment



Move field diaphragm image into center of field of view. Adjust its size to match field of view.

Figure 3-14 Field diaphragm adjustment

1. Move the 10x objective into the optical path.
2. Rotate the field diaphragm knob on the dia pillar illuminator until the field diaphragm image is visible in the field of view.
3. Adjust the focus onto the field diaphragm image by rotating the condenser focus knob on the dia pillar illuminator.
4. Move the field diaphragm image to the center of the field of view by rotating the two condenser centering knobs on the dia pillar illuminator.
5. Move the 40x objective into the optical path.
6. Adjust the size of the field diaphragm image to closely match the size of the field of view, by rotating the field diaphragm knob on the dia pillar illuminator.
7. Move the field diaphragm image to the center of the field of view by rotating the two condenser centering knobs on the dia pillar illuminator.

3.7 Aperture Diaphragm Operation

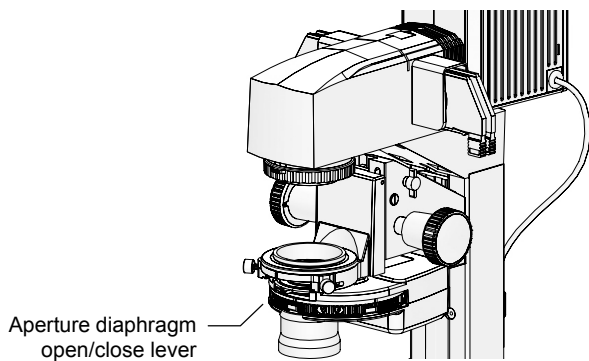
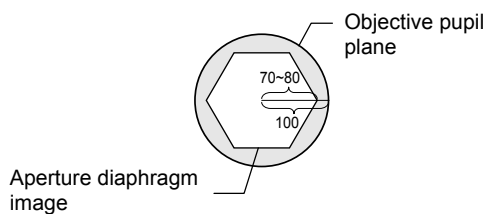


Figure 3-15 Aperture diaphragm open/close lever



Adjust the size of the aperture diaphragm image to 70-80% the size of the objective pupil plane.

Figure 3-16 Aperture diaphragm adjustment

The aperture diaphragm adjusts the numerical aperture of the illumination system.

By adjusting the aperture diaphragm, you can adjust the resolution, brightness, contrast, and focal depth of the microscope image. Closing the aperture diaphragm will reduce the resolution and brightness, and increase the contrast and focal depth. These properties are interrelated, and cannot be adjusted independently. Adjust the aperture diaphragm according to the specimen and purpose.

Aperture diaphragm adjustment is particularly important for bright-field microscopy, DIC microscopy, and photomicroscopy. Typically, adjusting the aperture diaphragm to 70-80% of the numerical aperture of the objective will result in an appropriate contrast and a favorable image.

Adjust the aperture diaphragm while looking at the actual diaphragm image. Move the aperture diaphragm open/close lever to the left to reduce the aperture size, or to the right to increase the aperture size. Adjust the aperture diaphragm so that the size of the diaphragm image is at 70-80% of the size of the objective pupil plane.

Adjustment with Bertrand lens on eyepiece tube

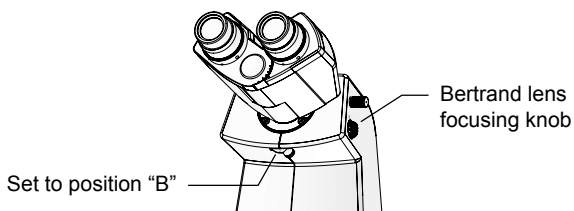


Figure 3-17 Adjustment with Bertrand lens

When using TI-TD Eyepiece Tube B or TI-TERG Ergonomic Eyepiece Tube, use the Bertrand lens in the eyepiece tube for adjustment.

Move the Bertrand lens into the optical path by moving the Bertrand lens in/out lever at the lower front of the eyepiece tube to position "B." Rotate the Bertrand lens focusing knob on the right to adjust the focus. This will allow you to view the objective pupil plane (a bright circle) and the aperture diaphragm image.

Adjustment with centering telescope

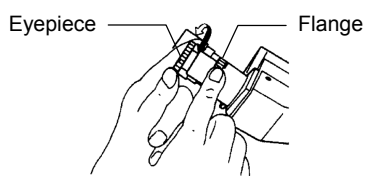


Figure 3-18 Adjustment with centering telescope

When using TI-TS Eyepiece Tube B, use the centering telescope for adjustment.

Remove one of the eyepieces. Using the adapter, attach a centering telescope instead. Rotate the eyepiece of the centering telescope to adjust the focus. This will allow you to view the objective pupil plane (a bright circle) and the aperture diaphragm image.

Precautions on condenser and aperture diaphragm

- Be sure to fully open the aperture diaphragm when performing phase contrast microscopy with the TI-C Condenser Turret. If the aperture diaphragm is not fully open, the optical path will be blocked.
- The aperture diaphragm of the ELWD-S condenser is used only for bright-field microscopy. This aperture diaphragm is independent of the phase contrast annular diaphragm. Adjustment of the aperture diaphragm will not affect the annular diaphragm.

3.8 Condenser Operation

3.8.1 TI-C Condenser Turret (System Condenser)

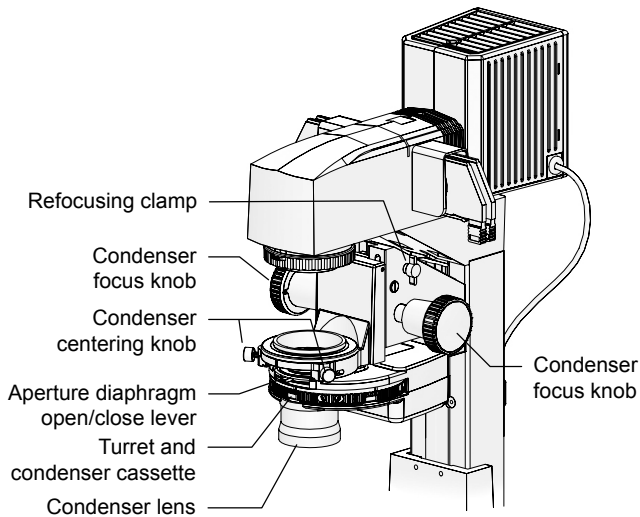


Figure 3-19 TI-C Condenser Turret (system condenser)

The condenser has two functions: the first is to focus the dia illumination light, and the second is to apply optical modulation to enable the various microscopy methods.

Traditionally, the condenser had to be changed depending on the microscopy method.

On the other hand, a system condenser can have up to five condenser cassettes in its turret, each with different optical elements. Thus, the microscopy method can be changed simply by rotating the turret.

The condenser cassettes can be freely arranged on the turret, as long as they are compatible with the condenser lens (there are three types). Condenser cassettes can be changed without removing the condenser from the microscope, allowing several microscopy methods to be used within a short time span.

When using the TI-CT-E Motorized Condenser Turret, refer to the instruction manual provided with TI-HUBC/A Hub Controller A.

Phase contrast microscopy

When performing phase contrast microscopy, use a condenser cassette that has the same Ph code as the objective and the external phase contrast ring, and center the annular diaphragm after moving the condenser cassette into the optical path. Be sure to fully open the aperture diaphragm. If the aperture diaphragm is not fully open, the optical path will be blocked.

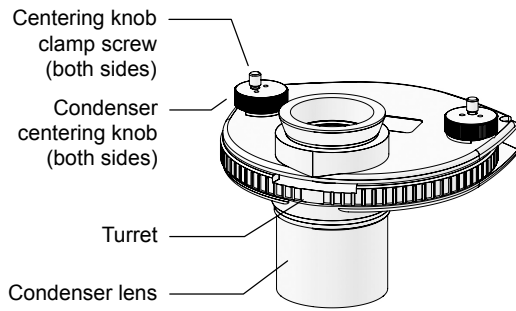
Comparison of condenser lenses

The following three types of condenser lenses can be attached to the TI-C Condenser Turret.

Table: Comparison of condenser lenses

	LWD condenser lens	CLWD condenser lens	ELWD condenser lens
NA	0.52	0.72	0.3
Working distance	30 mm	13 mm	75 mm
Supported microscopy methods	Bright-field, phase contrast, DIC	Bright-field, phase contrast	Bright-field, phase contrast
Supported condenser cassettes	Bright-field: A Phase contrast: PhL, Ph1, Ph2, Ph3 DIC: DIC L, DIC M, DIC H HMC: MC1, MC2, MC3	Bright-field: A Phase contrast: Ph1, Ph2, Ph3, Ph4	Bright-field: A Phase contrast: PhL, Ph1, Ph2
Remarks	Supporting condenser refocus clamp	Requires TI-DF condenser adapter.	

3.8.2 ELWD-S Condenser



The ELWD-S Condenser supports bright-field microscopy and phase contrast microscopy. The ELWD-S Condenser can be used with both 100W and 30W pillar illuminators.

Figure 3-20 ELWD-S Condenser

3.9 Eyepiece Tube Operation

3.9.1 Diopter Adjustment

Diopter adjustment corrects the difference in the left and right fields of view, making binocular observation easier. The eyepiece tube length will be maintained, allowing for the objective to perform optimally with minimal focus loss upon objective change.

To perform diopter adjustment, follow the instructions below.

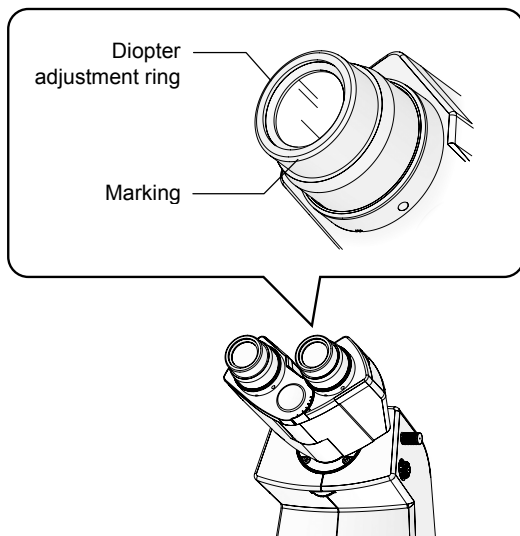


Figure 3-21 Diopter adjustment

1. **Under bright-field microscopy, adjust the focus of the 10x objective onto the specimen.**
2. **On each eyepiece, rotate the diopter adjustment ring to align its lower end with the marking on the eyepiece.**

This will be the reference position for diopter adjustment.

3. **Move the 40x objective into the optical path.**
4. **Look into the left eyepiece with your left eye. Adjust the focus onto the specimen by rotating the focus knobs.**
5. **Move the 10x objective into the optical path.**
6. **Look into the left eyepiece with your left eye. Adjust the focus onto the specimen by rotating the diopter adjustment ring on the left eyepiece.**

Do not touch the focus knobs at this time.

7. **Repeat steps 3 through 6 two times.**
8. **Adjust the right eyepiece.**

Repeat steps 2 through 7, but this time using the right eyepiece instead of the left.

3.9.2 Interpupillary Distance Adjustment

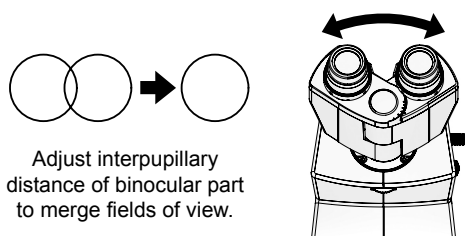


Figure 3-22 Interpupillary distance adjustment

Interpupillary distance adjustment adjusts the distance between the eyepieces to better suit the user. This will make binocular observation easier.

When diopter adjustment is complete, move the 10x objective into the optical path, and adjust the focus onto the specimen. Look into the eyepieces with both eyes, and adjust the interpupillary distance of the binocular part so that the two fields of view overlap into one.

The binocular part has an interpupillary distance scale. It is recommended that you remember your own interpupillary distance for easier adjustment in the future.

3.9.3 Eyepiece Tube Shutter Operation

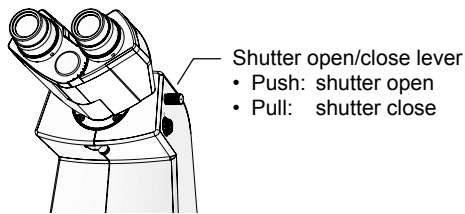


Figure 3-23 Shutter open/close lever

TI-TD Eyepiece Tube B and TI-TERG Ergonomic Eyepiece Tube have a built-in manual shutter mechanism.

Pull out the shutter operation lever on the right side of the eyepiece tube to push the shutter into the optical path. Push in the lever to the limit to open the shutter.

* TI-TS Eyepiece Tube B is not equipped with a built-in shutter.

3.9.4 Bertrand Lens Operation

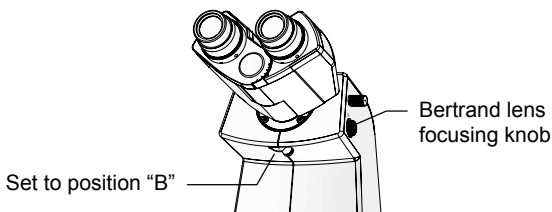


Figure 3-24 Bertrand lens operation

TI-TD Eyepiece Tube B and TI-TERG Ergonomic Eyepiece Tube have a built-in Bertrand lens.

Move the Bertrand lens into the optical path by moving the Bertrand lens operation lever at the lower front to position "B." Rotate the Bertrand lens focusing knob on the right to adjust the focus. This will allow you to view the objective pupil plane (a bright circle) and the aperture diaphragm image.

Position	Optical element	Description
O	Blank	Use to observe the microscope image with the eyepiece tube.
B	Bertrand lens	Use to observe the objective pupil plane. Use the focusing knob to adjust the focus onto the pupil plane. The Bertrand lens is used for aperture diaphragm adjustment, as well as for centering during phase contrast microscopy. It can also be used to observe the tip of the manipulator above the objective, if using a manipulator.

* TI-TS Eyepiece Tube B is not equipped with a Bertrand lens.

3.10 Focusing Mechanism Operation

3.10.1 Focus Knob Operation

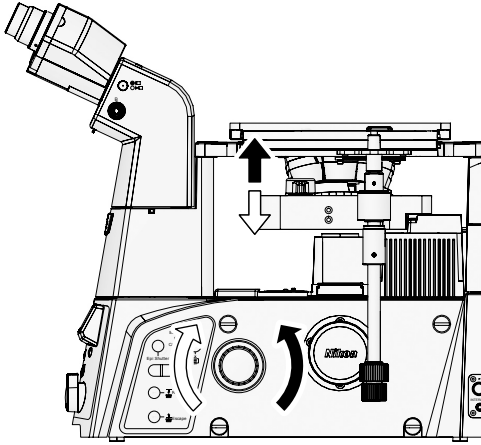


Figure 3-25 Focus knobs and nosepiece movement

Ti-E has a motorized focusing mechanism. The nosepiece can be moved up and down by rotating the focus knobs on the sides of the microscope body. The figure on the left illustrates the relationship between the rotational direction of the focus knobs and the vertical motion of the objective.

- * The stroke for focus adjustment is approximately 7.5 mm upward and approximately 2.5 mm downward from the reference position.

Focus knob resolution selector

The resolution for focus knob rotation can be set to one of the following three levels:

Setting	Distance traveled per rotation
Coarse	300 μm per rotation (reference value) *
Fine	50 μm per rotation
ExFine (extra fine)	6.25 μm per rotation

- * When set to COARSE mode, the distance traveled by rotating a focus knob will vary depending on how fast the knob is rotated.

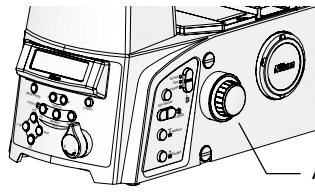
Focus knob resolution, Z-axis position display

The current focus knob resolution and Z-axis position will be displayed on the status display panel on the front.

- Display example for Z-axis position and focus knob resolution

```
Z: +124.225um
E100 Fine
```

3.10.2 Z-RESET Switch Operation



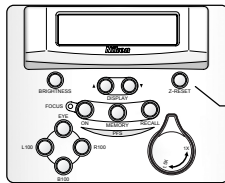
Adjust focus.

```
Z: 128.735um
E100 Coarse
```

Z-axis position
is displayed.

The Z-axis position of the focus mechanism, displayed on the status display panel, increases when the nosepiece is elevated, and decreases when the nosepiece is lowered.

Once you have set the focus at the desired height, pressing the Z-RESET switch on the front operation panel and resetting the Z-axis position display will allow you to use the set position as a reference point for focus adjustment.



Press Z-RESET switch.

```
Z: 0.000um
E100 Coarse
```

Z-axis position
display is reset.

Figure 3-26 Z-RESET switch operation

3.10.3 Retraction and Refocusing of Objective

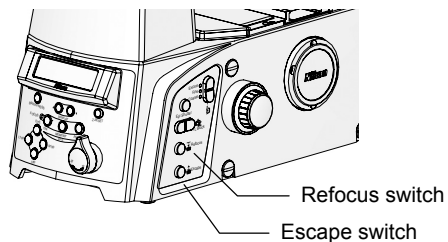


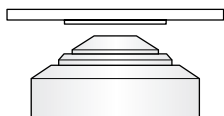
Figure 3-27 Escape switch, Refocus switch

The Escape switch (objective retraction) and Refocus switch (objective refocusing) on the right side of the microscope can be used to move the objective to and back from the retracted position (approximately 2 mm below the reference position).

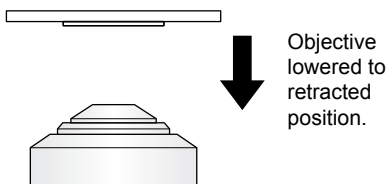
With the focus on the specimen, press the Escape switch to record the current position and lower the objective to the retracted position. The objective can be brought back up to the focused position by pressing the Refocus switch, making refocusing easier. This function is useful for temporarily moving the objective out of the way, for example when replacing the specimen or changing the objective.

- When the objective is at the retracted position, its height cannot be adjusted by rotating the focus knobs.

(1) Adjust the focus.



(2) Press the Escape switch.



(3) Press the Refocus switch.

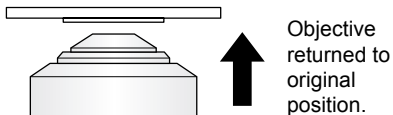


Figure 3-28 Retraction and refocusing of objective

When using the TI-ND6-PFS Perfect Focus Unit or the TI-ND6-E Motorized Sextuple DIC Nosepiece in combination with the TI-RCP Remote Control Pad, the system can be set to retract and refocus the objective automatically when the objective is switched. For details, refer to the instruction manual provided with the TI-RCP Remote Control Pad.

3.11 Objective Operation

3.11.1 Phase Contrast Objectives

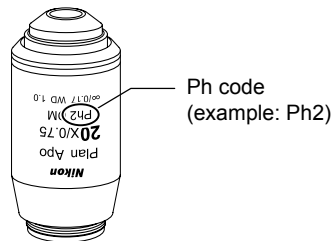


Figure 3-29 Phase contrast objective (example)

Phase contrast objectives are labeled with a “Ph code” (PhL, Ph1, Ph2, or Ph3). When performing phase contrast microscopy, use an annular diaphragm or condenser cassette that has the same Ph code as the objective, regardless of the magnification of the objective.

3.11.2 Cover Glass Thickness

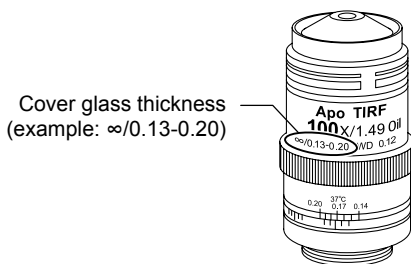


Figure 3-30 Cover glass thickness (example)

Objectives are labeled with the supported cover glass thickness. For example, “∞/0.17” indicates a cover glass thickness of 0.17 mm.

When observing at high magnification through glass that is thicker than the supported glass thickness (i.e. when observing a specimen in a Petri dish), it is recommended that you use an objective with a correction ring so that the optical system can be adjusted accordingly. (See Section 3.11.3, “Objectives with Correction Ring”)

Glass thickness of 0.17 mm

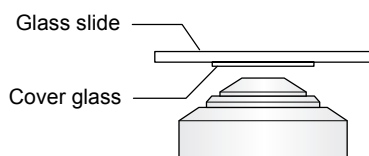


Figure 3-31 Glass thickness of 0.17 mm

When using an objective labeled “0.17”, face the cover glass downward, and set the specimen so that the cover glass faces the objective. (The cover glass has a thickness of 0.17 mm.)

Glass thickness of 1.2 mm

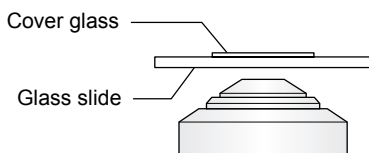


Figure 3-32 Glass thickness of 1.2 mm

When using an objective labeled “1.2”, face the cover glass upward, and set the specimen so that the glass slide faces the objective. (The glass slide has a thickness of 1.2 mm.)

3.11.3 Objectives with Correction Ring

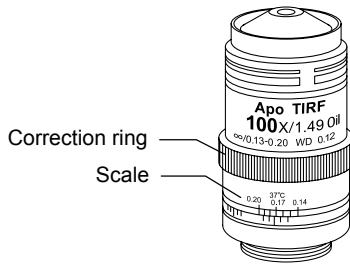


Figure 3-33 Objective with correction ring (example)

Inverted microscopes are sometimes used to observe through the bottom plate (glass or plastic) of a Petri dish or a culture vessel. In such a case, the microscope may not perform optimally with standard objectives (for glass covers with a thickness of 0.17 mm), as the thickness of the bottom plate varies from container to container.

By using an objective with a correction ring, you will be able to compensate for the thickness of the bottom plate.

Note, however, that correction is not possible where there is a change in the thickness of the bottom plate (i.e. around the periphery of the container). Use the correction function where the thickness of the bottom plate is uniform.

Correction ring adjustment

1. **Adjust the objective correction ring to match the reading on the scale to the thickness of the container's bottom plate.**

For the thickness of the bottom plate, take an actual measurement or refer to the specifications provided by the manufacturer.

An acrylic concentric ring is useful as it will allow you to view the operating parts from above the stage as you work.

2. **Focus on the specimen by rotating the focus knobs.**
3. **If the resolution and contrast of the image are poor, slightly rotate the correction ring on the objective in either direction.**

This will shift the focus slightly. Readjust the focus by turning the focus knob.

4. **If resolution and contrast are improved, rotate the correction ring slightly in the same direction, and readjust the focus.**

If resolution and contrast are lost, rotate the correction ring in the opposite direction by approximately twice the amount rotated in the previous step. Readjust the focus.

Repeat the process to obtain the optimal image.

- It is recommended to note the optimal correction ring setting for use as reference in using containers of different thicknesses.
- The 0 mm position of the correction ring corresponds to the position for observing a no-cover-glass specimen on an upright microscope.

3.11.4 Oil Immersion Objectives

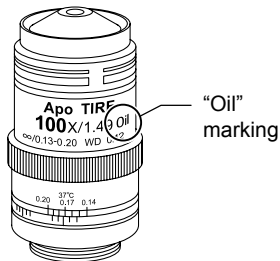


Figure 3-34 Oil immersion objective (example)

Objectives with the “Oil” label are oil immersion objectives.

When using an oil immersion objective, fill the space between the objective tip and the specimen with oil (Nikon Immersion Oil). When performing epi-fl microscopy with an epi-fl oil immersion objective, use non-fluorescent oil.

Applying Oil

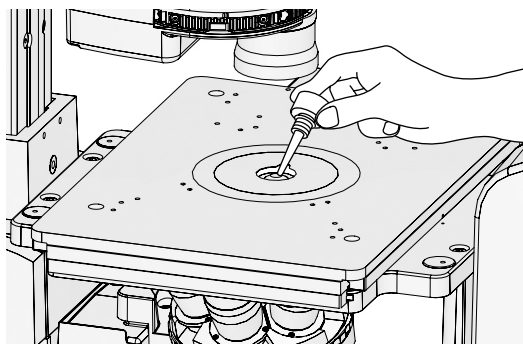


Figure 3-35 Applying oil immersion

1. Lower the objective by rotating the focus knobs.
2. Taking care not to let bubbles form, apply the bare minimum amount of oil onto the tip of the objective.

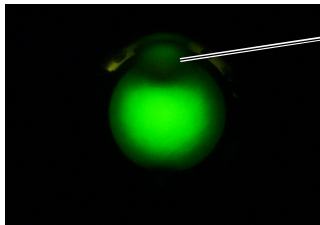
If too much oil is applied, the excess oil may overflow onto the stage and other parts. Use as little oil as possible (just enough to fill the space between the objective tip and the specimen), and take care not to allow the oil to get on other parts.

3. Place the specimen onto the stage.
4. Slowly raise the objective by rotating the focus knobs, allowing the oil to fill the space between the objective tip and the specimen.
5. Check that no air bubbles have formed in the oil.

Bubbles in the oil will adversely affect the viewing of the image. Refer to the following section and check for bubbles.

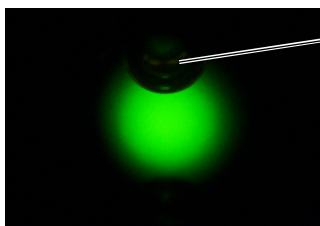
Checking for air bubbles

(1) Objective pupil plane under observation with Bertrand lens



Light partially blocked in upper section of field of view.

(2) Field of view with focus of Bertrand lens shifted from the above state



Air bubble recognized in upper section of field of view.

To check for air bubbles, observe the objective pupil plane. The objective pupil plane can be observed by rotating the Bertrand lens operation lever to position "B" and adjusting the focus with the Bertrand lens focusing knob, or by replacing an objective with a centering telescope and adjusting the focus with its eyepiece.

If you detect bubbles in the oil, attempt to remove them by rotating the nosepiece slightly to move the oil-immersed objective back and forth in the oil one or two times. If the bubbles cannot be removed, wipe off the oil, and reapply new oil.

Figure 3-36 Air bubble observation with Bertrand lens (example)

Removing oil

After using an oil immersion objective, wipe the oil off from its tip.

To remove the oil, gently wipe two or three times with a lens tissue or gauze dampened with petroleum benzine. It is recommended that you avoid using the same area of the tissue or gauze repeatedly. After wiping with petroleum benzine, wipe with absolute alcohol (ethyl or methyl) for a better finish.

If petroleum benzine is unavailable, use methyl alcohol. However, as methyl alcohol does not clean as well as petroleum benzine, it will be necessary to wipe a few more times. (Three to four wipes are usually sufficient.)

When wiping oil off of the specimen, take care not to damage the specimen.



Caution

- **Residual oil on an oil-immersion objective or oil adhered to the tip of a dry-type objective will degrade the image quality significantly. After use, thoroughly wipe off all oil, and make sure that no oil adheres to the tips of other objectives.**
- **Absolute alcohol and petroleum benzene are highly flammable. Handle with care. Do not use near an open flame, or operate a power switch in the vicinity.**

Reapplying oil

When performing oil immersion repeatedly, use the Escape and Refocus switches for faster focus adjustment.

A $\varnothing 25$ mm or acrylic concentric ring is useful as it will allow you to apply the oil via its oiling notch, without needing to remove the specimen (i.e. Petri dish). Set the concentric ring so that its notch matches the rotational direction of the nosepiece, hold the nosepiece so that the objective is aligned with the notch, and apply the oil.

3.11.5 Water Immersion Objectives

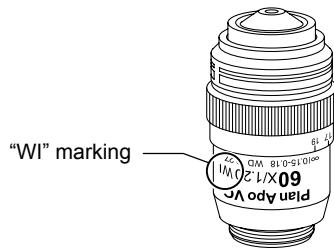


Figure 3-37 Water immersion objective (example)

Objectives with the “WI” label are water immersion objectives. (Those with long operating distances are for upright microscopes.)

When using a water immersion objective, fill the space between the objective tip and the specimen with deionized or distilled water.



Caution

- **Do NOT use tap water. If tap water is used, impurities may adhere to and solidify on the lens, causing the lens to become scratched when being cleaned.**
- **Plan Apo 60xWI (NA=1.2) is equipped with a correction ring to achieve optimal aberration on cover glasses of different thicknesses. A reading of “17” on the scale indicates 0.17 mm. When using a cover glass, measure the thickness of the cover glass with a micrometer, and adjust the correction ring for the thickness for a more accurate correction.**

3.12 Pillar Illuminator 100W Operation

This section describes operations specific to TI-DH Dia Pillar Illuminator 100W.

3.12.1 Condenser Refocusing Clamp

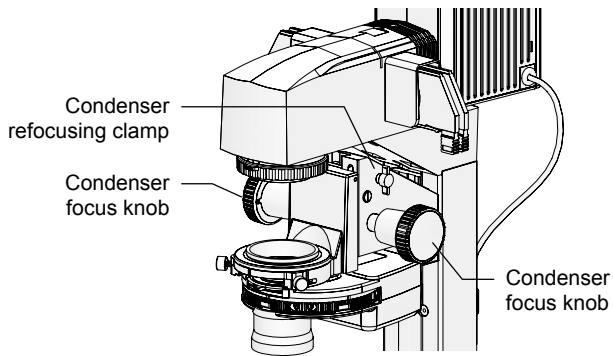


Figure 3-38 Pillar Illuminator 100W

Form the field diaphragm image on the specimen surface by rotating the condenser focus knob. Rotate the condenser refocusing clamp clockwise to the limit to mark this position.

When the condenser is elevated to change the specimen, it can easily be brought back down to the initial position (at which the field diaphragm image is formed) by rotating the condenser focus knob to the limit. This function is useful for use with high magnification condensers or when the pillar cannot be inclined. The condenser refocusing clamp has a range of motion of 13 mm.

3.12.2 Condenser Mount Rotation

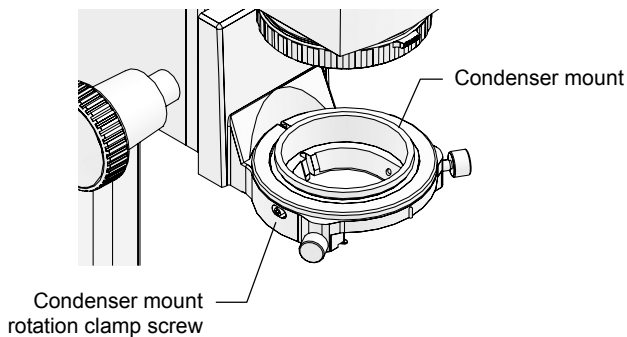


Figure 3-39 Condenser mount

The condenser mount can be rotated if the condenser mount rotation clamp screw is loosened.

Use this function to adjust the orientation of the turret when using the DIC attachment.

When using the system condenser without a polarizer on the condenser holder (i.e. for bright-field or phase contrast microscopy), this function can also be used to rotate and fix the turret. This will allow you to secure a space for manipulator attachment.

3.12.3 Pillar Inclination

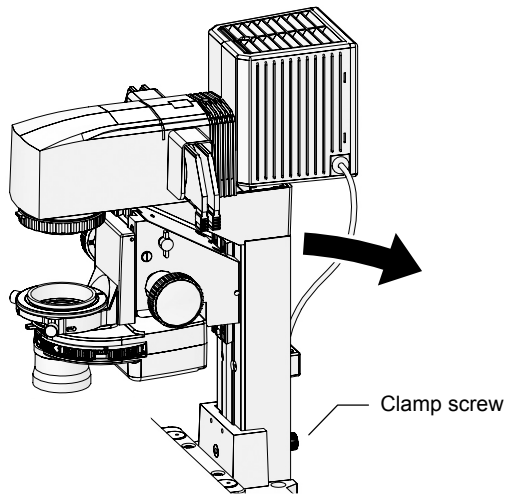


Figure 3-40 Pillar inclination

When replacing a large specimen, the pillar can be inclined to secure working space.

To incline the pillar, loosen and release the clamp screw on its back. Hold the front side of the dia illuminator, and slowly let the pillar incline backward.

Under normal use, the clamp screw on the pillar can be left released. However, be sure to tighten the clamp screw when attaching relatively heavy objects to the pillar, so as to prevent it from falling.



Caution

- When moving the pillar into and out of an incline, take caution not to get your hands and fingers caught in the hinge.
- When attaching relatively heavy objects to the pillar, be sure to secure them properly. A loose screw may result in the attachment falling off when the pillar is inclined. In particular, be sure to properly secure high-intensity lamphouses and lamphouse adapters.

3.12.4 Device Attachment Screw Holes

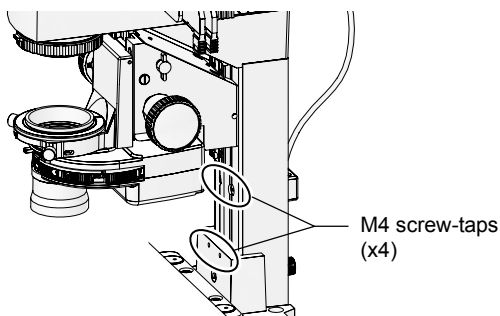


Figure 3-41 Device attachment screw holes

Four M4 screw-taps are provided on the front of the pillar for attaching devices such as manipulators.

Use the upper two holes to attach devices that should be moved out of the way when the pillar is inclined. Use the lower two holes to attach devices that should remain positioned over the stage when the pillar is inclined.

3.13 Rectangular Mechanical Stage Operation

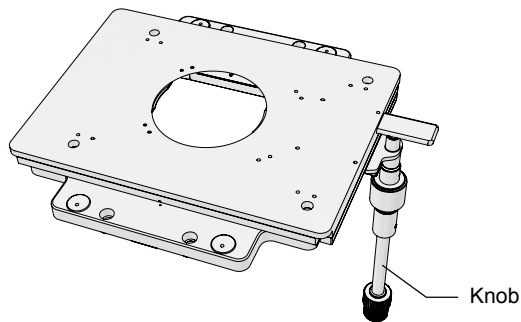


Figure 3-42 Rectangular Mechanical Stage

The knob on the rectangular mechanical stage uses a universal joint, and can be operated freely at any angle.

The stage is provided with screw-taps on both the top and bottom surfaces for attaching devices such as manipulators.

The rectangular mechanical stage is typically attached with the knob positioned in the far right. It is also possible to rotate the stage 180 degrees and attach it with the knob in the near left.

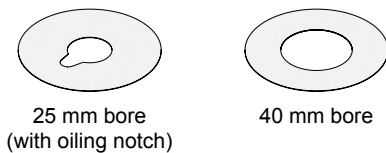


Figure 3-43 Concentric rings

Two concentric rings of different sizes are provided with the microscope ($\varnothing 25$ mm and $\varnothing 40$ mm). Use whichever is appropriate depending on the size of the specimen.

When using the 40 mm ring, the objective may collide with the bottom surface of the stage if the nosepiece is rotated with the stage moved out of the observation area. In such a case, first lower the nosepiece to the limit, and then switch the objective.



Caution

The stage rack will protrude when the stage is operated. When operating the focus knobs or the nosepiece, take caution not to strike your hands against the rack. Contact with the edges of the rack may result in injury.

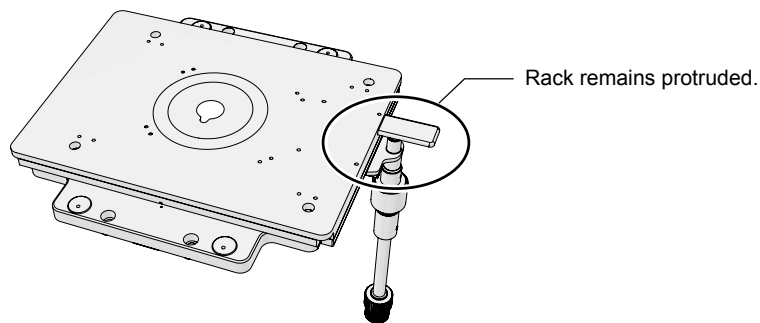


Figure 3-44 Rectangular Mechanical Stage Rack

3.14 PFS (Perfect Focus System) Operation

This section describes the operation of the PFS (Perfect Focus System).

To use PFS, attach the PFS Motorized Nosepiece and the PFS offset controller to Ti-E or Ti-E/B, and use PFS ready objectives. You will also need to register the objective information on the microscope. For assembly details, refer to Chapter 4, "Assembly."

3.14.1 PFS Overview

The PFS is used to keep focus for long-term observations. It automatically corrects focus drift caused by thermal expansion of the stage or temperature change of the specimen.

The PFS uses near-infrared rays (IR wavelength, 870 nm) that do not interfere with normal observations to detect the boundary surface ^(NOTE 1) between the cover glass ^(NOTE 2) and the aqueous solution of the specimen, and then maintains focus by automatically tracking the vertical shift of that surface.

It can be useful, for example when continuously observing or photographing changes in living cells, as it is not affected by changes in the specimen or by discoloration under fluorescent light, and is capable of maintaining the focus by compensating for minor focus shifts that may occur with time or by stage movements.

NOTE 1 : When using a dry objective, the boundary surface between the cover glass and air will be detected.

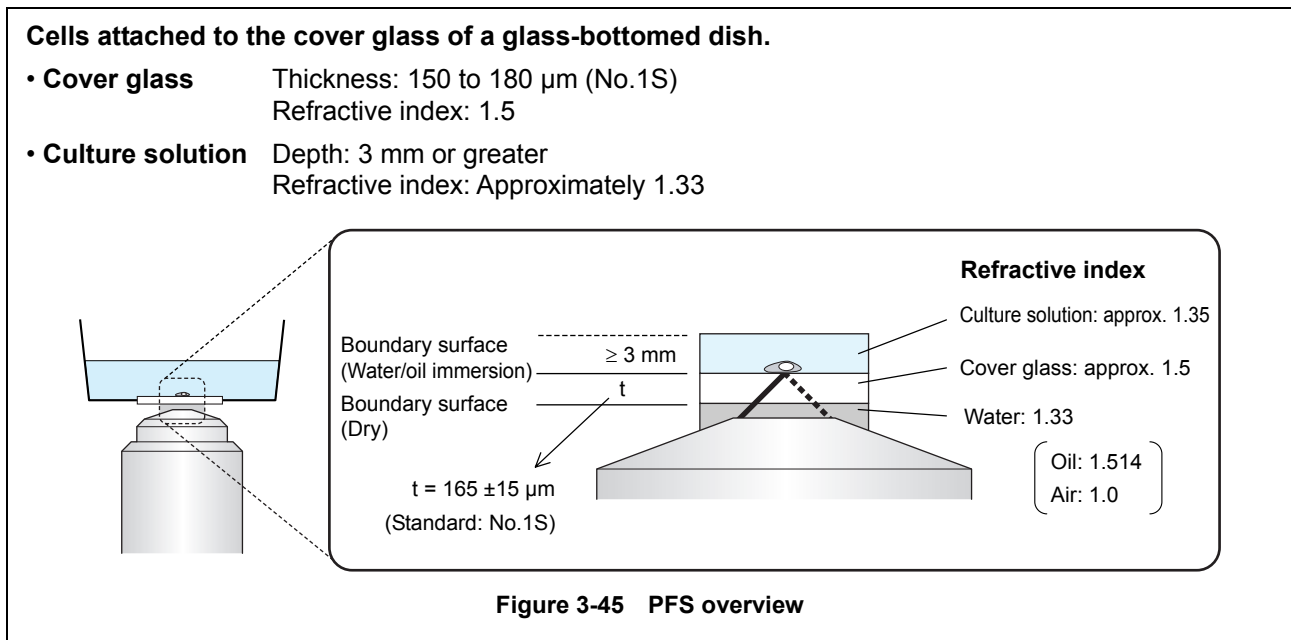
NOTE 2 : The "cover glass" refers to the glass on the bottom surface of a glass-bottomed dish.

Features of PFS

- The PFS uses infrared rays to keep focus. As infrared rays have minimal effect on the specimen, and do not interfere with fluorescent observation, the focus can be maintained while performing fluorescent observation.
- The optical offset function allows for manual adjustment of the focus position.
- The vertical position (Z-axis position) of the nosepiece and the focus offset can be registered independently for each objective.
- Focus can be maintained for any target within the field of view.
- Focus can be maintained with any observation camera or method (including macroscopic), unlike with the image contrast method that can only be used with certain cameras.

Supported specimens

The PFS function can be used with any specimen that satisfies the following conditions.



Unsupported specimens

In-focus observation with the PFS may be difficult on the following specimens, for reasons such as weak IR reflectivity or excessive scattered light.

1. Fixed specimens

In general, fixed specimens are filled with an encapsulating medium. Due to the high refractive index of this medium, the difference in the refractive index between the cover glass and the specimen is decreased. Thus, the amount of reflected light may be insufficient for surface detection.

2. Sliced specimens

Sliced specimens are thick, and scatter a large amount of light. This makes it difficult to capture the relatively small amount of reflective light from the boundary surface.

3. Specimens with large amounts of scattered or reflected light

For the same reason as for the sliced specimens, non-sliced specimens that scatter a large amount of light are also unsupported.

4. Cells attached to a container with a glass bottom thicker than 170 μm

When using a dry objective with a specimen in thick glass, the boundary surface may not be detectable due to insufficient offset. (The boundary surface may be detectable if using an oil immersion objective. However, use of No.1S cover glass is recommended.)

5. Plastic dishes

The use of plastic dishes is not recommended, as their boundary surfaces are not as precise as those of glass.

6. Dirty cover glasses (oil stains, dust)

The PFS maintains focus by detecting the boundary surface of the cover glass. Contaminations on the cover glass will degrade the precision of the detection. Be sure to clean the cover glass before use.

Supported objectives

The following objectives can be used for in-focus observation with the PFS. Use of other objectives will result in an error, and “PFS: ER1” will be displayed on the status display panel.

Table: PFS ready objectives

Model name	NA	WD (mm)	Type	Model name	NA	WD (mm)	Type
Apo TIRF 60xH	1.49	0.12	Oil	Plan Fluor 10x	0.3	16	Dry
Apo TIRF 100xH	1.49	0.12	Oil	Plan Fluor DLL 10x	0.3	16	Dry
Plan Apo 4x	0.2	15.7	Dry	Plan Fluor ELWD 20xC	0.45	7.4	Dry
Plan Apo 10x	0.45	4	Dry	Plan Fluor ELWD ADL 20xC	0.45	7.4	Dry
Plan Apo 20x	0.75	1	Dry	Plan Fluor ELWD DM 20xC	0.45	7.4	Dry
Plan Apo 40x	0.95	0.14	Dry	Plan Fluor 40x	0.75	0.72	Dry
Plan Apo DM 40x	0.95	0.14	Dry	Plan Fluor 40xH	1.3	0.2	Oil
Plan Apo 60xHA	1.4	0.21	Oil	Plan Fluor DLL 40x	0.75	0.72	Dry
Plan Apo 60xWI	1.2	0.22	WI	Plan Fluor ELWD 40xC	0.6	3.7-2.7	Dry
Plan Apo DM 60xHA	1.4	0.21	Oil	Plan Fluor ELWD ADL 40xC	0.6	3.7-2.7	Dry
Plan Apo DM 60xH	1.4	0.21	Oil	Plan Fluor ELWD DM 40xC	0.6	3.7-2.7	Dry
Plan Apo 100xH	1.4	0.13	Oil	Plan Fluor 100x H	1.3	0.2	Oil
Plan Apo DM 100xH	1.4	0.13	Oil	Plan Fluor ADH 100x H	1.3	0.19	Oil
Plan Apo TIRF 60xH	1.45	0.13	Oil	Plan Fluor DLL 100x H	1.3	0.2	Oil
Plan Apo TIRF 100xH	1.45	0.13	Oil	S Fluor 4x	0.2	15.5	Dry
Plan Apo VC 60xWI	1.2	0.27	WI	S Fluor 10x	0.5	1.2	Dry
Plan Apo VC 60xH	1.4	0.13	Oil	S Fluor 20x	0.75	1.00	Dry
Plan Apo VC 100xH	1.4	0.13	Oil	S Fluor DL 20x	0.75	1.00	Dry
				S Fluor 40xH	1.3	0.22	Oil
				S Fluor DL 40xC	0.9	0.3	Dry
				S Plan Fluor ELWD 20xC	0.45	8.2-6.9	Dry
				S Plan Fluor ELWD ADM 20xC	0.45	8.2-6.9	Dry
				S Plan Fluor ELWD 40xC	0.6	3.6-2.8	Dry
				S Plan Fluor ELWD ADM 40xC	0.6	3.6-2.8	Dry

To perform the PFS function, you will need to register the objective information on the microscope. For registration details, refer to Chapter 4, “Assembly.”

3.14.2 Starting and Stopping In-focus Observation with the PFS

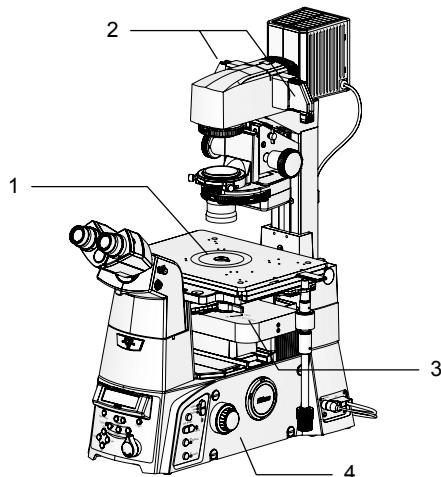


Figure 3-46 Preparation for in-focus observation

1. **Select an objective, and place a specimen onto the stage.**

Place a PFS ready objective into the optical path. (See “PFS ready objectives” on page 83.)
Perform water/oil-immersion procedures as necessary.

2. **Place an IR filter into the optical path.**

Attach an IR filter ($\varnothing 45$ mm) to the filter slider on the pillar illuminator, and then place the IR filter into the optical path.

For epi illumination, attach an IR filter ($\varnothing 25$ mm) to the filter sliders on the epi illuminator.

3. **Place the dichroic mirror into the optical path by moving the DICHROIC MIRROR - IN/OUT lever on the top of the PFS Motorized Nosepiece to the “IN” position.**

4. **Focus on the specimen by rotating the focus knobs on the microscope.**

5. **Start the PFS function by pressing the PFS-ON switch on the front operation panel.**

The PFS-ON switch indicator lights up, and the PFS function will start. The focus knobs will be disabled while the PFS function is running.

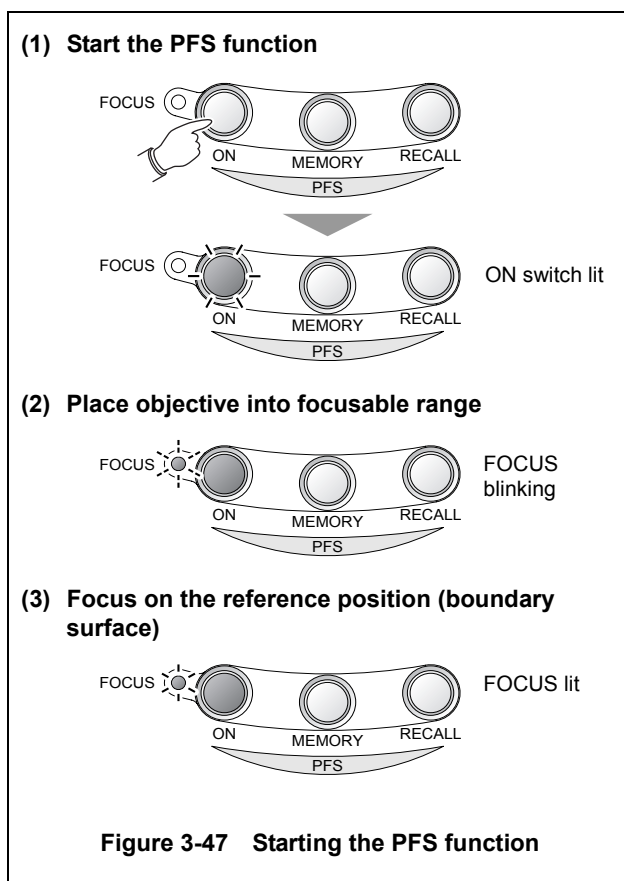
■ PFS function is running

```
PF100x Z: 124.375um
E100 Coarse PFS:On
```

When the objective enters the focusable range, the FOCUS indicator on the front operation panel will begin to blink. When the focus is on the reference position (boundary surface), the indicator will light up.

When the PFS function is enabled, the focus mechanism will be controlled automatically to maintain the focus on the reference position.

* The “focusable range” is defined for each objective, and is the region within which the PFS function is enabled for that objective.



3.14 PFS (Perfect Focus System) Operation

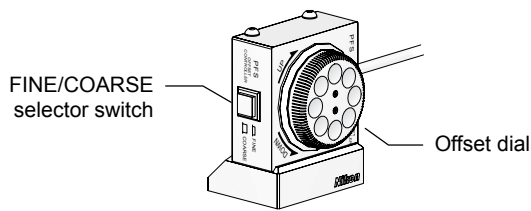


Figure 3-48 PFS Offset Controller

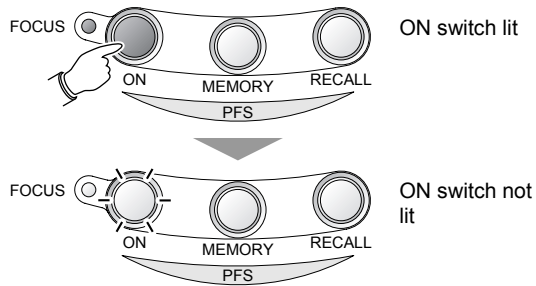


Figure 3-49 Stopping the PFS function

6. **Focus on the target of the specimen, by rotating the offset dial on the PFS offset controller.**

In step 5, the focus is set on the reference position, not on the actual target.

To set the focus on the actual target, adjust the offset by rotating the offset dial on the PFS offset controller. For details, refer to Section 3.14.3, "Offset Adjustment."

7. **To stop the PFS function, press the illuminated PFS-ON switch.**

The PFS-ON switch indicator turns off, and the PFS function stops.

Be sure to stop the PFS function before replacing the specimen or changing the objective.

8. **When observing without using the PFS function, remove the dichroic mirror out of the optical path by rotating the DICHROIC MIRROR - IN/OUT lever on the top of the PFS Motorized Nosepiece to the "OUT" position.**

3.14.3 Offset Adjustment

When the PFS function starts, the Z-axis position of the objective will track the vertical shift of the boundary surface. To shift the focus onto the desired position, rotate the offset dial on the PFS offset controller.

The offset dial moves the mirror in the PFS Motorized Nosepiece, allowing you to adjust the focus within the field of view, while maintaining the focused state.

The distance (i.e. the amount by which the focus was moved) from the reference position (boundary surface) to the position moved to with the offset dial is referred to as "offset." This offset will be maintained as the PFS function tracks the vertical shift of the boundary surface.

* The maximum offset varies depending on the objective. In particular, water/oil immersion objectives are limited in their downward offset.

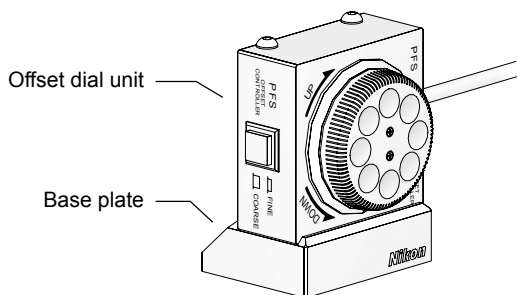


Figure 3-50 PFS Offset Controller

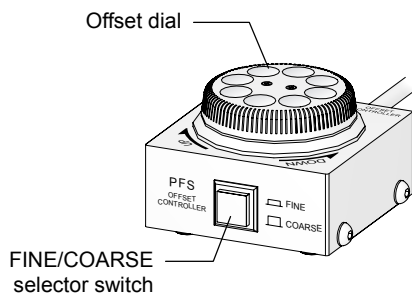


Figure 3-51 Offset adjustment

PFS Offset Controller operation

The PFS offset controller has an offset dial component and a base plate that are magnetically attached.

By changing the orientation of the dial component on the base plate, the dial can be faced to the left or the right. The dial can also be faced upward, if used alone without the base plate.

Offset adjustment

FINE/COARSE selector switch

The distance traveled by rotating the offset dial can be switched between FINE and COARSE. The selected state can be checked by whether the switch is pressed in.

Offset dial:

Adjusts the offset. Rotate clockwise to increase the offset (move the objective closer to the specimen), or counterclockwise to decrease the offset (move the objective further from the specimen).

- The offset dial is enabled only if the PFS function is ON (PFS-ON switch is lit).
- When using the 4x or the 10x objective, the offset can be adjusted with fine movements only, regardless of the FINE/COARSE switch setting.

3.14.4 Registration and Restoration of Offset

The offset set during observation can be registered on the microscope. By registering the offset, the offset can be easily restored after manual adjustments.

Registering the offset

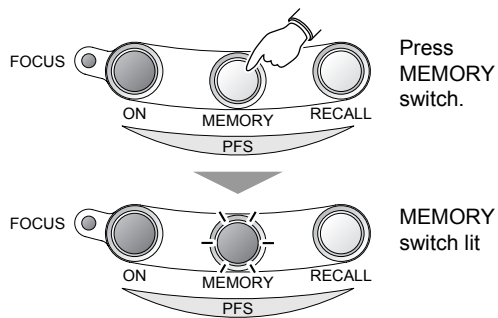


Figure 3-52 Registering the offset

1. **Start the PFS function. Focus on the target by rotating the offset dial on the PFS offset controller.**

2. **Press the MEMORY switch.**

The MEMORY switch indicator is lit, and the offset is registered.

- The registered offset will be overwritten each time the MEMORY switch is pressed.
- The offset can be registered independently for each objective on the nosepiece (max. 6).
- The registered offsets will be retained until the system is turned off.

Restoring the offset

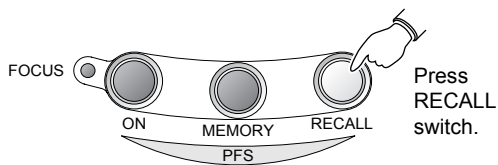


Figure 3-53 Restoring the offset

1. **Check that the MEMORY switch is lit.**

2. **Press the RECALL switch.**

The offset lens automatically moves to the registered offset position.

Manual operation with the focus knobs will be disabled during the restoration of the offset.

If an offset is not registered (MEMORY switch is not lit), the RECALL switch will restore the objective to the zero offset position (initial position).

Note that the focus position may not match the boundary surface exactly, depending on the thickness and material of the cover glass, as well as on other environment variables.

3.14.5 If the Objective is Changed

If the objective is changed while the PFS function is running, the PFS function will stop, and the objective will move as described below.

- **If an offset is registered:**

The objective moves to the registered offset position.

- **If an offset is not registered:**

The objective moves to the zero offset position (initial position). Note that the focus position may not match the boundary surface exactly, depending on the thickness and material of the cover glass, as well as on other environment variables.

* The objective will also move in the same manner if the objective is changed while the PFS function is running.

3.14.6 If the PFS Function Does Not Start

If “PFS: DIS” is displayed on the status display panel

There is no reference position (boundary surface) within the focusable range. Move the objective up and down by rotating the focus knobs. The PFS function will start once the boundary surface enters the focusable region.

If “PFS: Out” is displayed on the status display panel

The dichroic mirror is not in the optical path. Place the dichroic mirror into the optical path by moving the dichroic mirror operation lever on the top of the PFS nosepiece to the “IN” position.

Even if the focus is set on the boundary surface, the focus may not be set on the observation target. Adjust the offset as necessary, as described in Section 3.14.3, “Offset adjustment.”

In particular, when using a dry objective, difference in cover glass thickness may cause the initial position to differ from the boundary surface. In this case, focus on the observation target with the PFS offset controller, after the FOCUS indicator and the PFS-ON switch indicator light up.

Timeout function (dry objectives only)

If the boundary surface cannot be detected within 5 seconds after pressing the PFS-ON switch to start the PFS function, the vertical movement of the objective will stop to prevent collision with the specimen. This is the “timeout function.” For reference, the objective will move approximately 400 μm during the 5 seconds.

When the timeout function is activated, the system will beep, the PFS-ON switch indicator will turn off, and the vertical movement of the objective will stop.

If “PFS: ER2” is displayed on the status display panel

The timeout function is activated. As there is no reference position (boundary surface) within the detectable range, manually focus on the specimen, and then press the PFS-ON switch again.

4

Assembly



Warning

- Before assembling or connecting devices, thoroughly read the “Safety Precautions” at the beginning of this manual, and heed all warnings and cautions written therein.
- To prevent electric shock, fire, and product damage, turn off the power switch on all devices, and unplug the power cords.



Caution

- Take care to avoid pinching your fingers and hands.
- Scratches and dirt on optical components (i.e. lenses and filters) will degrade the microscope image. Keep them free of scratches, dust, fingerprints, and other dirt.
- The product is a precision optical instrument. Handle the product with care, and avoid subjecting it to strong physical shocks. In particular, the accuracy of objectives may be lost by even weak physical shocks.



Caution

Notes on setup

- To use the PFS Motorized Nosepiece, you will need to register the objective information on the microscope. After assembling the product, connect a PC and set up the microscope before use.
- For setup, use the “Ti Control” setup software for Ti series. For details on using the software and setting up the microscope, refer to the “Ti Control” instruction manual.

This chapter describes the installation, assembly, and setup of the product in the actual sequence. Assemble the product as described in this chapter.

When using Ti-E or Ti-E/B with TI-HUBC/A Hub Controller A



Refer to the instruction manual provided with TI-HUBC/A Hub Controller A

Required tools

- 2 mm hex screwdriver (x2) (included with product)
- 3 mm hex wrench (x1) (included with product)
- 4 mm hex screwdriver (x1) (included with product)

Installation conditions

Refer to the “Notes on Handling the Product” at the beginning of this manual and install the product in an appropriate location.

Checking the power supply voltage

When using TE-PS30W Power Supply A or TE-PSE30 Power Supply A with the product, check that the input voltage indicated on the power supply device matches the power voltage in your area. If the voltages do not match, do not use the power supply, and contact Nikon. Use of a power supply with the incorrect voltage rating may result in malfunctions, electric shock, or fire.

Assembly diagram

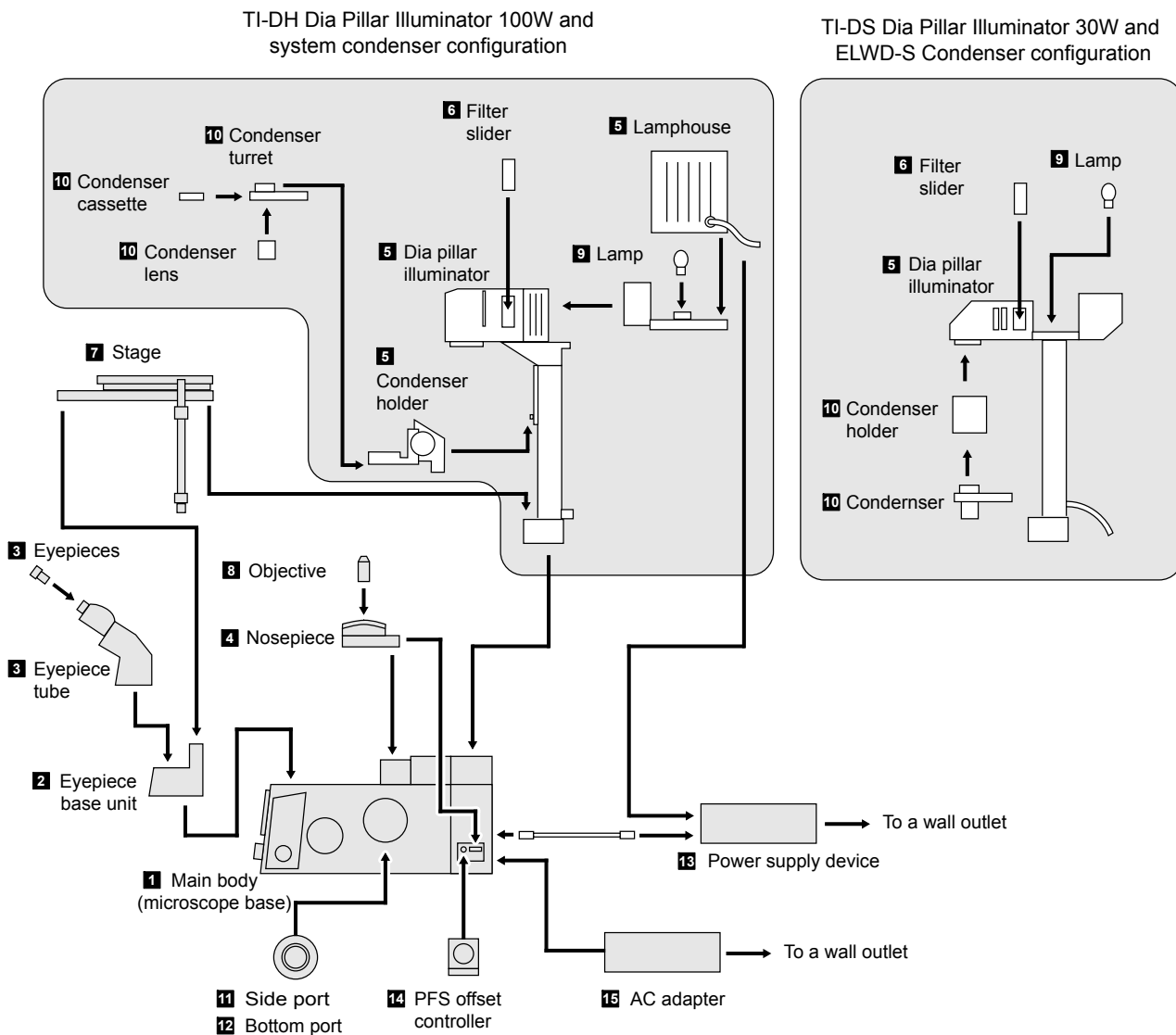


Figure 4-1 Assembly diagram

1 Installing the microscope body (microscope base)

Install the microscope in an appropriate location.

1. Select a location for the installation.

For the installation location, refer to “Installation location and storage location” in “Notes on Handling the Product” at the beginning of this manual.

2. Take out the main body (microscope base) from the box and place it on a stable surface.

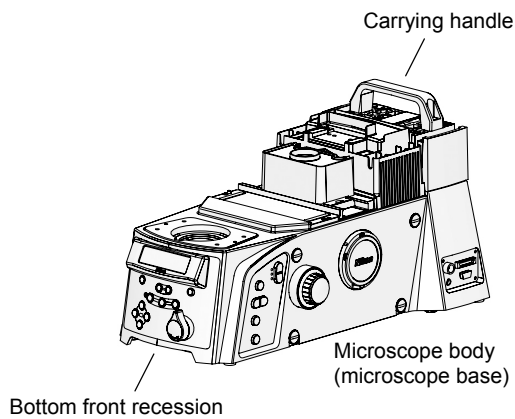


Figure 4-2 Microscope body installation

Notes on installation

- The microscope base is heavy. Be sure to move the microscope in a group of two or more people.
- When lifting the microscope base, hold it securely by the recess at the bottom front and the carrying handle at the rear.

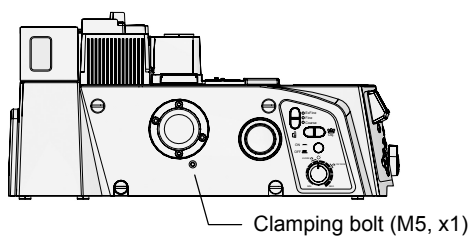


Figure 4-3 Clamping bolt

3. Remove the clamping bolt.

A clamping bolt is attached to the left side of the body to secure the product during transportation. Remove the clamping bolt with the provided 4 mm hex screwdriver, and attach the provided rubber cap to the clamping bolt hole.

If power is turned on with the clamping bolt left attached, it will prevent the observation from being performed, and may also cause product damage. Be sure to remove the clamping bolt before turning on the power.

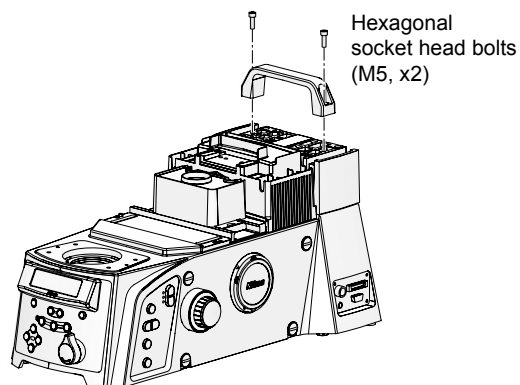


Figure 4-4 Carrying handle removal

4. Remove the carrying handle by loosening the two hex socket head screws with the provided 4 mm hex screwdriver.

2 Attaching the eyepiece base unit

(1) Attaching TI-T-B, TI-T-BS

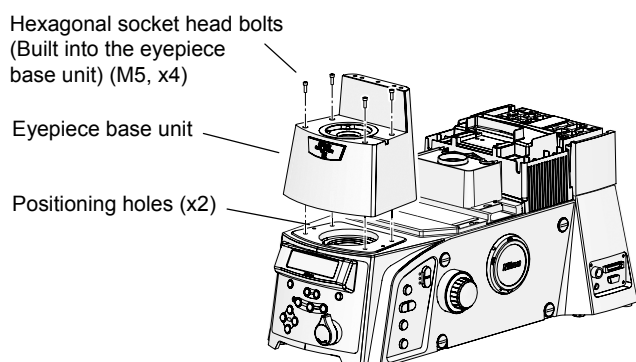


Figure 4-5 Eyepiece Base Unit attachment (TI-T-B, TI-T-BS)

1. Place the eyepiece base unit onto the front part of the microscope base, so that the eyepiece tube mount of the eyepiece base unit faces the front.

There are two positioning pins on the bottom of the eyepiece base unit. Align these pins with the holes on the microscope base.

2. Secure the eyepiece base unit by tightening four hex socket head screws with the provided 4 mm hex screwdriver.

(2) Attaching the TI-T-BPH External Phase Contrast Eyepiece Base Unit

To perform external phase contrast microscopy, attach an external phase contrast eyepiece base unit onto the microscope base, and attach a phase plate suitable for the selected condenser lens and objective to the eyepiece base unit.

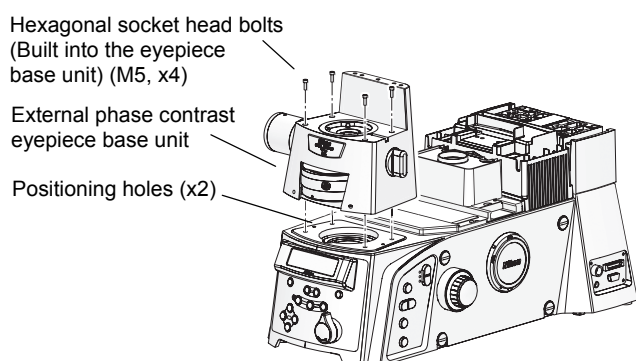


Figure 4-6 External phase contrast eyepiece base unit attachment

1. Place the TI-T-BPH External Phase Contrast Eyepiece Base Unit onto the front part of the microscope base.

There are two positioning pins on the bottom of the eyepiece base unit. Align these pins with the holes on the microscope base.

2. Secure the eyepiece base unit by tightening four hex socket head screws with the provided 4 mm hex screwdriver.

Selecting objectives and phase plates

The phase plate must be selected to suit the objective being used. Refer to the following table to select an objective and an appropriate phase plate. Up to three phase contrast plates (A, B, and C) can be attached to an external phase contrast eyepiece base unit.

	Condenser phase contrast code (Supported condenser lens)	Objective	External phase contrast ring
1	Ph3 (LWD, CLWD)	P Apo 60x WI (NA1.2)	60x/Ph3
2	Ph3 (LWD, CLWD)	P Apo VC 60x WI (NA1.2)	60x/Ph3
3	Ph3 (LWD, CLWD)	P Apo VC 60x H (NA1.4)	60x/Ph3
4	Ph4 (CLWD)	Apo TIRF 60x H (NA1.49)	60x/Ph4
5	Ph4 (CLWD)	P Apo TIRF 60x H (NA1.45)	60x/Ph4
6	Ph3 (LWD, CLWD)	P Apo VC 100x H (NA1.4)	100x/Ph3
7	Ph4 (CLWD)	Apo TIRF 100x H (NA1.49)	100x/Ph4

Attaching and replacing phase plates

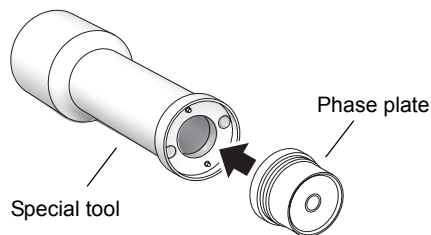


Figure 4-7 Special tool and phase plate

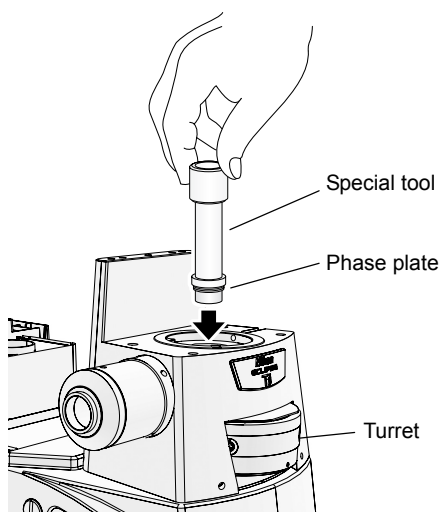


Figure 4-8 Attaching/replacing the phase plate

Phase plate attachment

A special tool is included with TI-T-BPH Eyepiece Base Unit. Use this special tool when attaching or replacing the phase plate.

1. **Align the holes on the phase plate to the two pins on the end of the special tool, and attach the phase plate to the tool.**

The phase plate will be attached magnetically to the special tool.

2. **Select position A, B, or C by rotating the turret on the external phase contrast eyepiece base unit.**
3. **Insert the special tool and the phase plate into the optical path hole on the top of the eyepiece base unit. Screw in the phase plate into the socket on the turret.**
4. **Remove the special tool and affix the provided label below the indication on the front of the turret.**
5. **Repeat steps 1 thru 4 for positions A thru C, as necessary.**

Phase plate replacement

1. **Select position A, B, or C by rotating the turret on the external phase contrast eyepiece base unit.**
2. **Insert the special tool into the optical path hole on the eyepiece base unit. Align the two pins on the special tool to the holes on the phase plate.**
3. **Remove the phase plate from the socket by rotating the tool counterclockwise.**
4. **Remove the phase plate by pulling out the special tool.**

The phase plate is attached magnetically to the special tool, and can be retrieved by lifting the tool.

5. **Attach other phase plate as described above in “Phase plate attachment.”**

3 Attaching the eyepiece tube and eyepieces

Attach the eyepiece tube to the eyepiece base unit, and the eyepieces to the binocular part of the eyepiece tube.

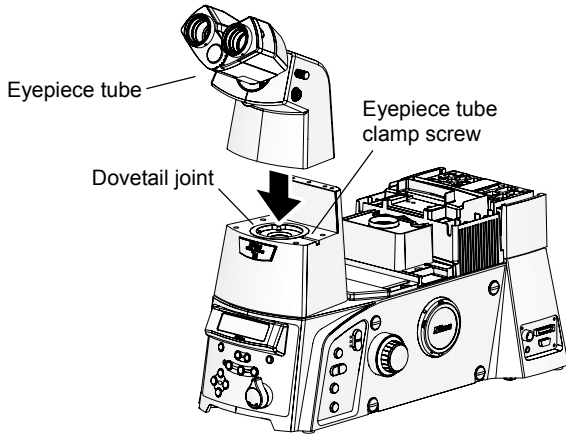


Figure 4-9 Eyepiece tube attachment

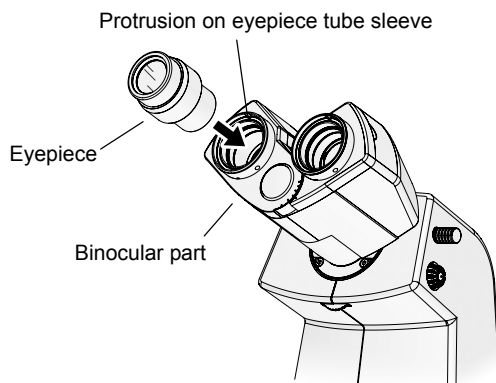


Figure 4-10 Eyepiece attachment

1. Using a 2 mm hex screwdriver, loosen the eyepiece tube clamp screw at the observation port on the front of the eyepiece base unit.
2. Mount the eyepiece tube onto the eyepiece base unit and insert the male circular dovetail joint on the bottom of the eyepiece tube into the female circular dovetail joint on the eyepiece base unit.
3. Tighten the eyepiece tube clamp screw with a 2 mm hex screwdriver. Check that the eyepiece tube and the eyepiece base unit are fixed securely.
4. Attach the eyepieces to the binocular part of the eyepiece tube.

When inserting, align any one of the three grooves on the eyepiece to the protrusion on the eyepiece tube sleeve. Select the same magnification for both left and right eyepieces.

To use rubber eye guards, attach them to the eyepieces.

4 Attaching the nosepiece

Attach the nosepiece to the rectangular groove on the focusing part at the center of the microscope base.

(1) Attaching the PFS Motorized Nosepiece

When using an FL turret, attach the Protection Plate (for PFS6 Nosepiece) supplied with the Perfect Focus Unit between the FL turret and the nosepiece. For details, refer to “(3) Attaching the protection plate (when using an FL turret)”.

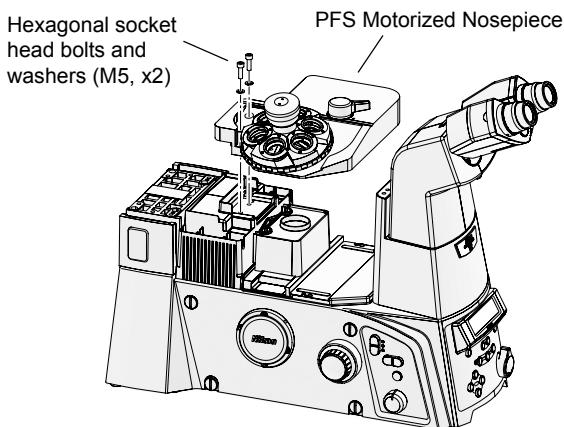


Figure 4-11 PFS Motorized Nosepiece attachment

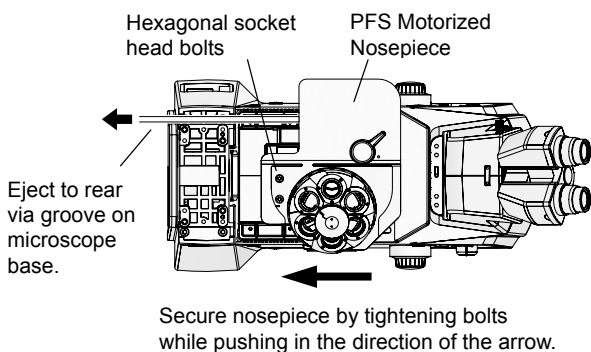


Figure 4-12 Fixing the PFS Motorized Nosepiece (top view)

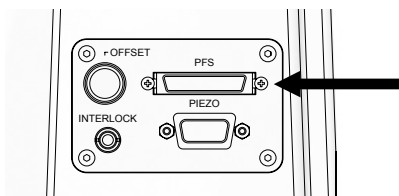


Figure 4-13 PFS connector (right connector panel)

1. **Adjust the orientation of the PFS Motorized Nosepiece, and place it on the rectangular groove on the focusing part at the center of the microscope base.**

2. **Press the PFS Motorized Nosepiece from the front to the rear, and secure it by tightening the two M5 hex socket head screws provided with the nosepiece.**

Be sure to use washers with the hex socket head screws.

3. **Guide the cable from the PFS Motorized Nosepiece through the groove on the microscope base, to the back of the microscope.**

Be sure to guide the cable through the groove on the microscope base, so that it does not interfere with the operation of the microscope.

4. **Connect the cable from the PFS Motorized Nosepiece to the PFS connector on the side of the microscope.**

Do not attach the objectives until the stage has been attached.

(2) Attaching a manual nosepiece

When using an FL turret, attach the Protection Plate (for the Nosepiece) supplied with Ti-E and Ti-E/B between an FL turret and the nosepiece. For details, refer to “(3) Attaching the protection plate (when using the FL turret)”.

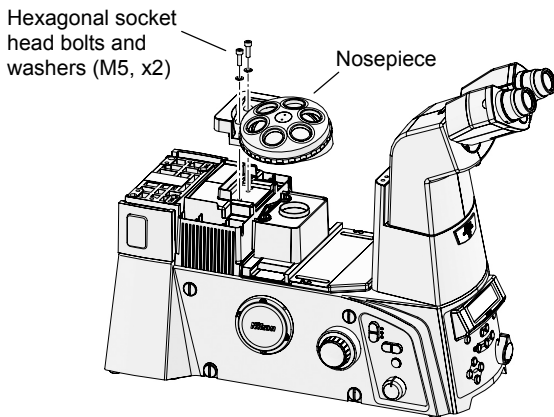
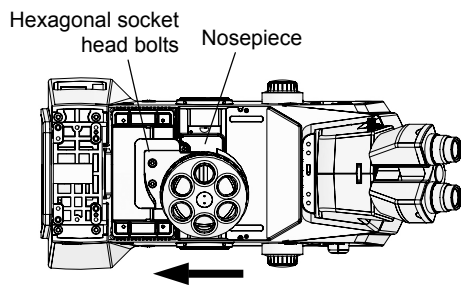


Figure 4-14 Nosepiece attachment

1. **Adjust the orientation of the nosepiece, and place it on the rectangular groove on the focusing part at the center of the microscope base.**
2. **Press the nosepiece from the front to the rear, and secure it by tightening the two M5 hex socket head screws provided with the nosepiece.**

Be sure to use washers with the hex socket head screws.

Do not attach the objectives until the stage has been attached.



Secure nosepiece by tightening bolts while pushing in the direction of the arrow.

Figure 4-15 Fixing the nosepiece (top view)

(3) Attaching the protection plate (when using an FL turret)

When using an FL turret with Ti-E or Ti-E/B, a protection plate must be attached between the FL turret and the nosepiece. The required protection plate will differ depending on the nosepiece. Follow the procedures below to attach the correct protection plate.

When using the TI-ND6-PFS PFS Motorized Nosepiece

The Protection Plate (for the PFS6 Nosepiece) supplied with the TI-ND6-PFS Perfect Focus Unit covers the gap between the PFS Motorized Nosepiece and the FL turret (TI-FLC, TI-FLC-E, or TI-FLC-E/HQ), so as to prevent injury caused by your hands and fingers getting caught.

When using an FL turret, attach the Protection Plate (for the PFS6 Nosepiece) before attaching the PFS Motorized Nosepiece, as described below.

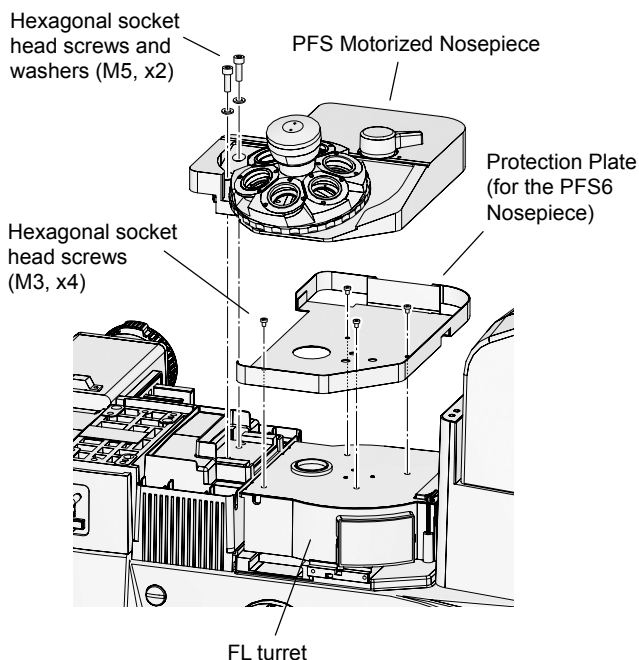


Figure 4-16 Protection Plate (for the PFS6 Nosepiece) attachment

1. Using a 2 mm hex screwdriver provided with Ti-E or Ti-E/B, remove the four M3 hex socket head screws from the top of the FL turret, as shown in the figure at left.
2. Attach the Protection Plate (for the PFS6 Nosepiece) onto the top of the FL turret. Insert and tighten the four M3 hex socket head screws that were removed in step 1.
3. Pass the connection cable from the PFS Motorized Nosepiece through the cable through-hole on the protection plate. Using the 4 mm hex screwdriver provided with Ti-E or Ti-E/B, secure the nosepiece to the microscope.

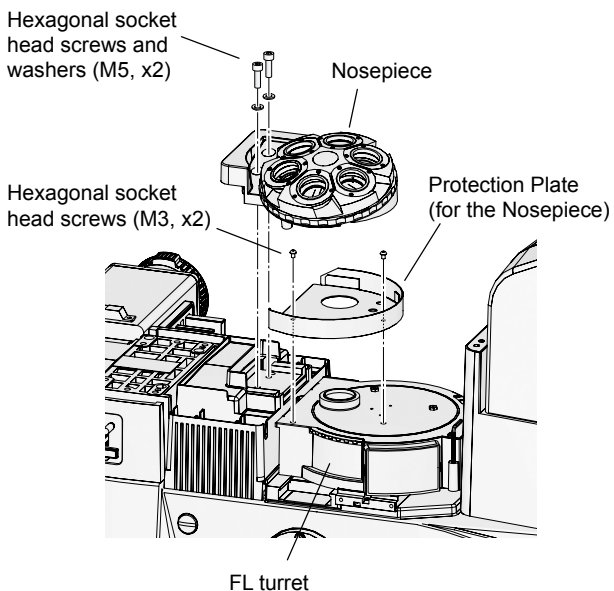
For details on attaching the PFS Motorized Nosepiece, refer to “(1) Attaching the PFS Motorized Nosepiece.”

When using other motorized nosepieces, refer to “Motorized Units for Ti Series Instructions.”

When using the TI-N6, TI-ND6, or TI-ND6-E nosepiece

The Protection Plate (for the Nosepiece) included with the Ti-E or Ti-E/B microscope covers the gap between the nosepiece (TI-N6, TI-ND6, or TI-ND6-E) and the FL turret (TI-FLC, TI-FLC-E, or TI-FLC-E/HQ), so as to prevent injury caused by your hands and fingers getting caught.

When using an FL turret, attach the Protection Plate (for the Nosepiece) before attaching the nosepiece, as described below.



1. Using a 2 mm hex screwdriver, remove two of four M3 hex socket head screws from the top of the filter turret (TI-FLC, TI-FLC-E, or TI-FLC-E/HQ), as shown in the figure at left.
2. Attach the Protection Plate (for the Nosepiece) onto the top of the FL turret. Insert and tighten the two M3 hex socket head screws that were removed in step 1.
3. Attach the nosepiece (TI-N6, TI-ND6, or TI-ND6-E) to the Ti-E or Ti-E/B microscope body, and secure with the 4 mm hex screwdriver.

For details on attaching the nosepiece, refer to “(2) Attaching a manual nosepiece”.

When using motorized nosepieces other than the PFS Motorized Nosepiece, refer to “Motorized Units for Ti Series Instructions.”

Figure 4-17 Protection Plate (for the Nosepiece) attachment

5 Attaching the dia pillar illuminator

Attach the dia pillar illuminator to the microscope base.

The TI series microscopes can be used with two types of dia pillar illuminators (100W and 30W).

(1) Attaching the TI-DH Dia Pillar Illuminator 100W

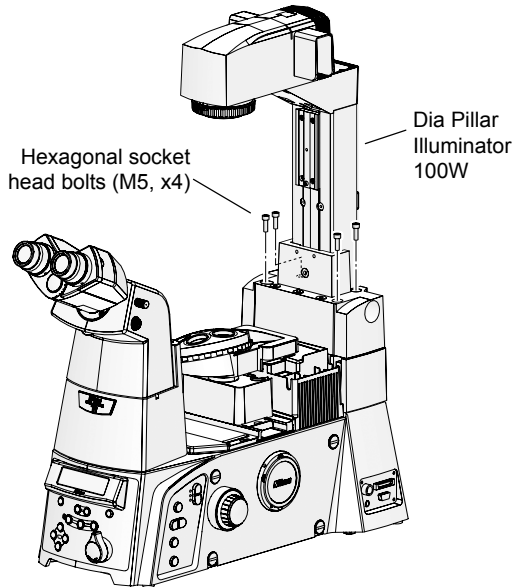


Figure 4-18 Dia Pillar Illuminator 100W attachment

Attach TI-DH Dia Pillar Illuminator 100W to the microscope base.

When working, hold the dia pillar illuminator to prevent it from falling.

1. Mount the dia pillar illuminator onto the microscope base.

A positioning pin is provided on the microscope base. Align the pinhole on the dia pillar illuminator to the positioning pin.

2. Using the 4 mm hex screwdriver, secure the dia pillar illuminator by tightening the four M5 hex socket head screws provided with the dia pillar illuminator.

3. Attach the condenser mount to the dia pillar illuminator.

(1) Remove the fall-stop screw.

(2) Attach the condenser mount by sliding it onto the dovetail groove on the dia pillar illuminator.

Slide the mount upward to the limit.

(3) Using a hex screwdriver, securely tighten the clamp screw on the right of the condenser mount.

(4) Attach the fall-stop screw.

(5) When using a condenser lens other than ELWD or ELWD-S, loosen the clamp screw on the condenser mount and slide the condenser mount downward to the fall-stop screw, and then tighten the clamp screw securely in this position.

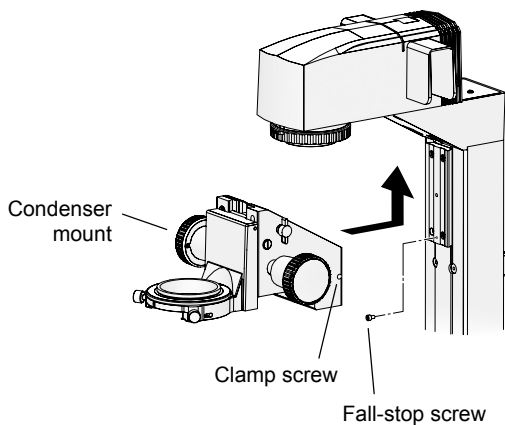


Figure 4-19 Condenser mount attachment

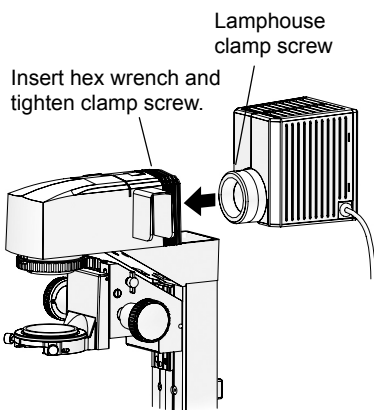


Figure 4-20 Lamphouse attachment

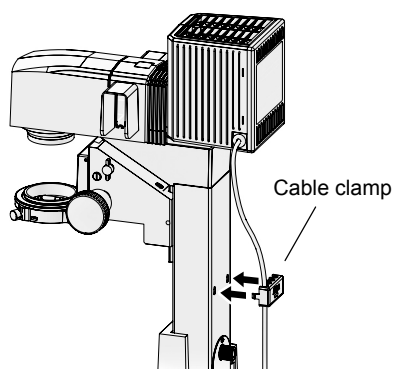


Figure 4-21 Fixing the cable

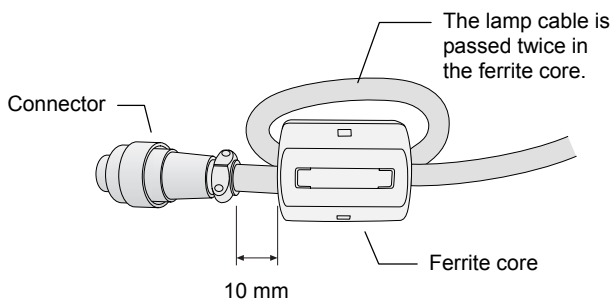



Figure 4-22 Ferrite core attachment

4. Attach the lamphouse to the dia pillar illuminator.

 **CAUTION: HOT** - Do not touch the lamp and the lamphouse while the lamp is on or for thirty minutes after it has been turned off.

- (1) Insert the lamphouse into the lamphouse mount at the top of the dia pillar illuminator. Align the positioning pin on the dia pillar illuminator with the groove on the cylinder of the lamphouse.
- (2) Insert a hex screwdriver into the hole on the top of the dia pillar illuminator. Secure the lamphouse by tightening the lamphouse clamp screw.
- (3) Secure the lamphouse cable with the cable clamp on the back of the dia pillar illuminator. The cable clamp is attached to the dia pillar illuminator with the hooks on its sides. To remove the cable clamp, push in the hooks from the sides. The cable clamp can hold up to four cables.

5. Attach the provided ferrite core on the connector end of the lamp cable.

- (1) Snap open the ferrite core.
- (2) Wrap the lamp cable once around the ferrite core, so that the cable passes through the ferrite core twice. Adjust the position of the ferrite core so that it is approximately 10 mm from the lamp cable connector.
- (3) Close the ferrite core.

* For details on connecting the lamphouse, the power supply device, and Ti-E or Ti-E/B, refer to "13. Connecting the power supply device."

(2) Attaching the TI-DS Dia Pillar Illuminator 30W

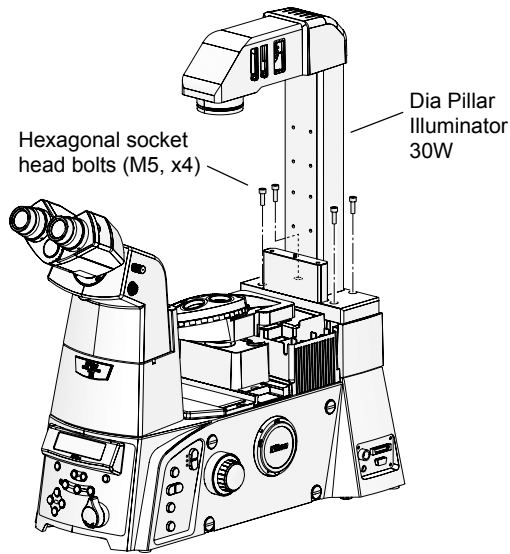


Figure 4-23 Dia Pillar Illuminator 30W attachment

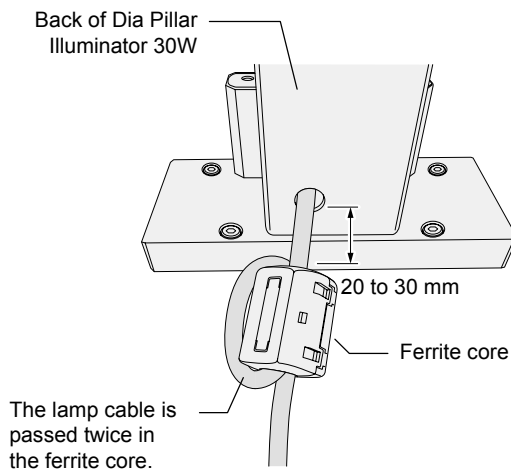


Figure 4-24 Ferrite core attachment

Attach TI-DS Dia Pillar Illuminator 30W to the microscope base.

When working, hold the dia pillar illuminator to prevent it from falling.

1. Mount the dia pillar illuminator onto the microscope base.

A positioning pin is provided on the microscope base. Align the pinhole on the dia pillar illuminator to the positioning pin.

2. Using the 4 mm hex screwdriver, secure the dia pillar illuminator by tightening the four M5 hex socket head screws provided with the dia pillar illuminator.

3. Attach the provided ferrite core on the pillar end of the lamp cable.

(1) Snap open the ferrite core.

(2) Wrap the lamp cable once around the ferrite core, so that the cable passes through the ferrite core twice.

Adjust the position of the ferrite core so that it is approximately 20 to 30 mm from the pillar.

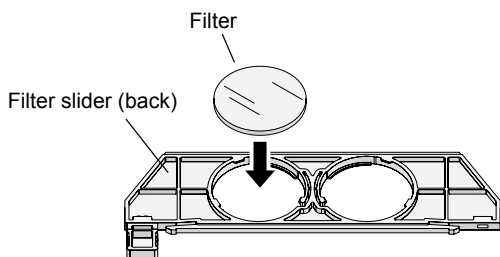
(3) Close the ferrite core.

* For details on connecting the lamphouse, the power supply device, and Ti-E or Ti-E/B, refer to "13. Connecting the power supply device."

6 Attaching the filter slider

Attached the desired filter to the filter slider, and attach the filter slider to the slot of the dia-illuminator.

Do not touch filters or other optical components with your bare hands.



Although the filter slider for the 30W dia-illuminator has a different shape, the method for securing the filters is the same.

Figure 4-25 Attaching filters

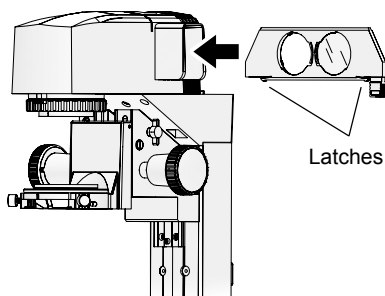


Figure 4-26 Inserting filter sliders (for Dia Pillar Illuminator 100W)

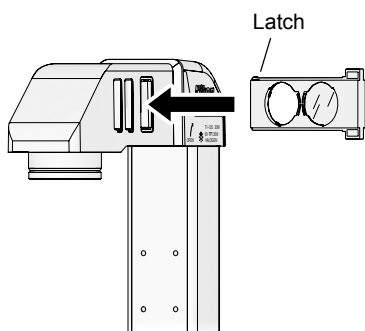


Figure 4-27 Inserting filter sliders (for Dia Pillar Illuminator 30W)

1. Attach the desired filter to the filter slider.

Attach it from the back of the filter slider. The mounting hole has three tabs to keep the filter from falling. Only one tab can be moved to the side. Move this tab aside, and attach the filter.

2. Affix a label indicating the filter type on the tab of the filter slider.

3. Insert the filter slider into the slot of the dia pillar illuminator.

The filter slider has latches that determine the limit of slide operation. Press the latches up, and press the filter into the slot.

You can insert up to four filter sliders for 100 W type illuminator and three filter sliders for 30 W type illuminator.

You can insert filters sliders from the right or the left. If they are all inserted from the same direction, they will be difficult to handle, so you should insert them alternately from the left and right.

To maintain uniformity with the Dia Pillar Illuminator 100W, install the diffusion filter (filter slider D) into the slot nearest to the lamphouse.

Removing a filter slider

Latches at both ends of the filter slider are at their end point when sliding. When removing a filter slider, you can slide it out by pushing the latch on the opposite side up with your finger to release the filter slider. Applying undue force on the filter slider can break the latches.

7 Attaching the stage

Attach the stage to the microscope base.

If objectives are attached to the nosepiece, remove them before attaching the stage.

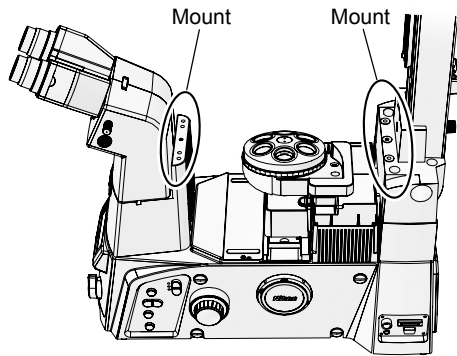


Figure 4-28 Stage mounts

1. **Place the stage onto the mounts at the base of the eyepiece base unit and at the base of the dia pillar illuminator.**

Positioning pins are provided on the mount at the base of the dia pillar illuminator. Align the holes on the bottom of the stage to these pins.

Stages with a stage movement knob are typically attached with the knob positioned in the far right. However, they can also be rotated by 180 degrees and be attached with the knob in the near left.

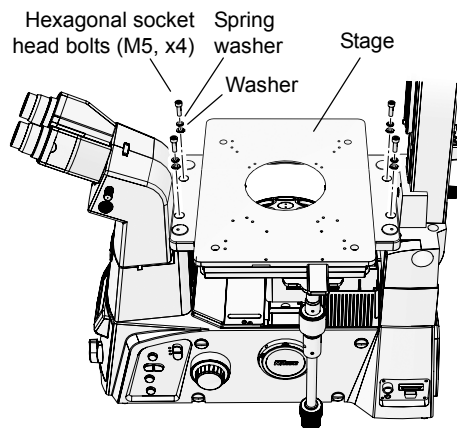


Figure 4-29 Stage attachment

2. **Secure the stage by tightening the four M5 hex socket head screws provided with the stage.**

Be sure to use spring washers and washers with the hex socket head screws.

8 Attaching objectives

Attach objectives to the nosepiece.

If the stage has not been attached, first attach the stage.

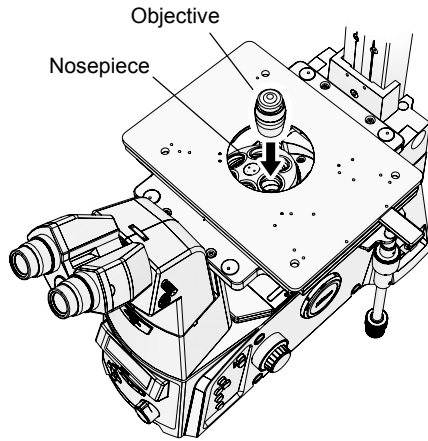


Figure 4-30 Objective attachment

1. **Remove the concentric ring, specimen holder, and other equipment from the stage.**
2. **Screw in an objective into a socket on the nosepiece through the opening in the stage.**

Attach the objectives so that magnification is increased by rotating the nosepiece clockwise (as viewed from above).

9 Replacing the dia illumination lamp



Caution

- The lamp, the dia pillar illuminator, and the power supply must be used in specific combinations. See page 55 to select the correct combination of the devices. Be sure to use the specified lamps.
- When replacing the lamp, turn off the power switch and unplug the power cord.
- The lamp and its surroundings will be hot while the lamp is on and immediately after it is turned off. When replacing the lamp, wait approximately 30 minutes after turning off the lamp, and make sure that the lamp has cooled sufficiently before working.
- Do not touch the lamp glass with your bare hands. Fingerprints and other dirt on the lamp may result in uneven illumination and reduce the service life of the lamp. Wear gloves when handling the lamp.
- Securely close the lamphouse cover after replacing the lamp. Never turn on the lamp with the cover removed.

(1) For TI-DH Dia Pillar Illuminator 100W

Insert hex wrench and loosen clamp screw.
Remove the lamphouse cover. (Clamp screw remains attached to the cover.)

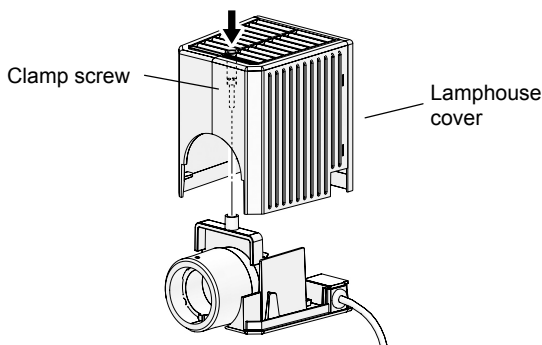
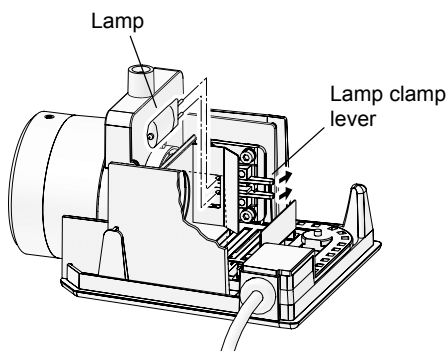


Figure 4-31 Lamphouse Cover Removal



Push in lamp clamp lever to open pin hole on socket.
Remove used lamp while pushing in lever. Attach new lamp.

Figure 4-32 Lamp Replacement



CAUTION: HOT - Do not touch the lamp and the lamphouse while the lamp is on or for thirty minutes after it has been turned off.

1. Insert a hex wrench into the hole on the top of the lamphouse cover. Loosen the clamp screw and remove the lamphouse cover.
2. Push in the lamp clamp lever and remove the used lamp from the socket.
3. Insert a new lamp into the socket.
While pushing in the lamp clamp lever, push the lamp electrodes (pins) into the pinhole in the socket. Insert the lamp to the limit, and release the lamp clamp lever.
 - Be sure to use the specified lamp.
 - Do not touch the lamp glass with your bare hands.
 - Make sure the lamp is not tilted when the lamp clamp lever is released.
4. Re-attach the lamphouse cover, and secure it by tightening the clamp screw.

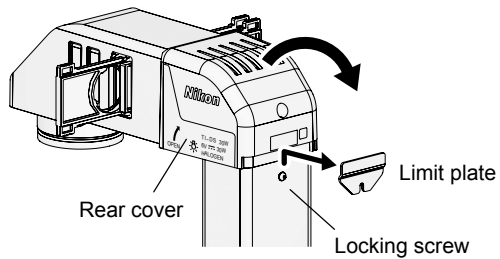
(2) For TI-DS Dia Pillar Illuminator 30W

Figure 4-33 Rear cover of the lamphouse

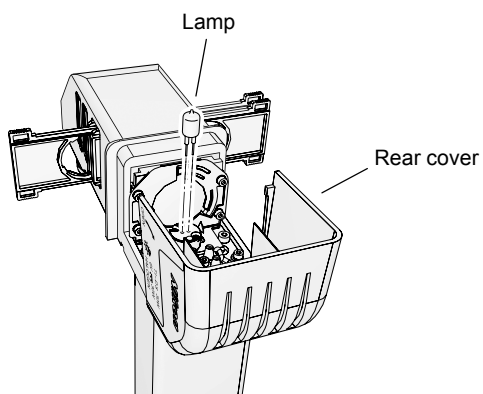


Figure 4-34 Replacing lamps



CAUTION: HOT - Do not touch the lamp and the lamphouse while the lamp is on or for thirty minutes after it has been turned off.

1. **Loosen the locking screw on the back of the dia pillar illuminator, and remove the limit plate from the rear cover.**
2. **Open the rear cover on the back of the dia pillar illuminator by lifting it backward.**
3. **Remove the used lamp from the socket.**
4. **Insert a new lamp into the socket.**
 - Be sure to use the specified lamp.
 - Do not touch the lamp glass with your bare hands.
5. **Close the rear cover.**
6. **Re-attach the limit plate onto the rear cover, and secure it by tightening the locking screw.**

10 Attaching the condenser

(1) Attaching to TI-DH Dia Pillar Illuminator 100W

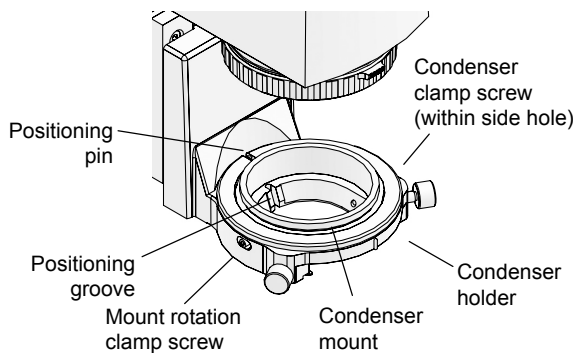


Figure 4-35 Condenser Holder

The following condensers can be attached to TI-DH Dia Pillar Illuminator 100W:

- TI-C Condenser Turret (system condenser)
- ELWD-S Condenser

(1) Preparation for attachment

Using a hex screwdriver, loosen the condenser clamp screw on the right side of the condenser holder.

- * The condenser clamp screw is located inside the hole on the right side of the condenser holder. If the condenser mount is shifted from the reference position, the screw will not be visible in the hole. In that case, loosen the condenser mount rotation clamp screw, align the positioning groove on the mount with the positioning pin on the condenser holder by rotating the mount, and then tighten the mount rotation clamp.

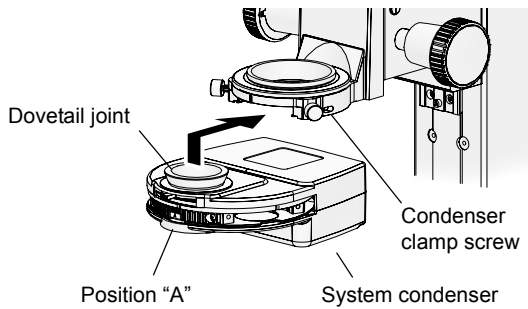


Figure 4-36 System condenser attachment

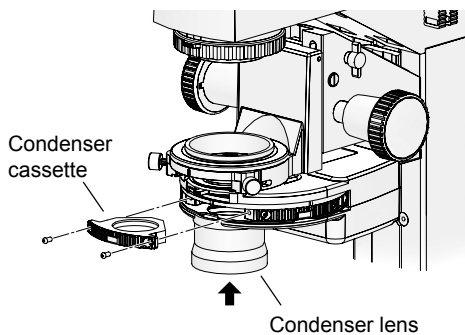


Figure 4-37 Condenser cassette and condenser lens attachment

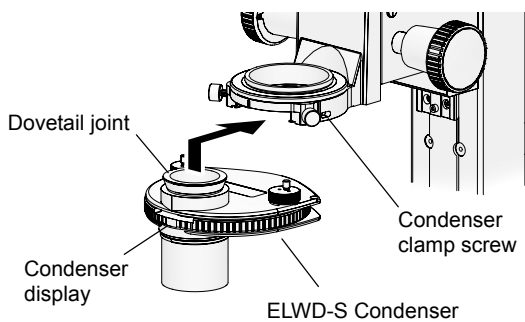


Figure 4-38 ELWD-S Condenser attachment

(2) Attaching the system condenser

1. Rotate the condenser turret to the "A" position (vacant hole cassette position for bright-field microscopy).
2. With the "A" label facing the front (towards yourself), insert the circular dovetail joint on the system condenser into the bottom of the condenser holder, and secure it by tightening the condenser clamp screw.

Attach the condenser turret by sliding it in from the front.

3. Insert the condenser cassette into the condenser turret, and secure it with two hex socket head screws.

Up to five condenser cassettes can be attached to the turret. Attach the cassettes so that their numbering is increased by rotating the turret clockwise (as viewed from above).

4. Screw in the condenser lens into the bottom of the turret.

For combinations of condenser lenses and condenser cassettes, see Chapter 3, "Operation."

(3) Attaching the ELWD-S condenser

With the indication on the turret facing the front (towards yourself), insert the condenser turret into the bottom of the condenser holder, and secure it by tightening the condenser clamp screw.

(2) Attaching to TI-DS Dia Pillar Illuminator 30W

The following condensers can be attached to TI-DS Dia Pillar Illuminator 30W:

- ELWD-S Condenser
- HMC Condenser

(1) Attaching the ELWD-S condenser

1. Secure the condenser holder to the dia pillar illuminator.
2. Attach the ELWD-S condenser to the condenser holder.

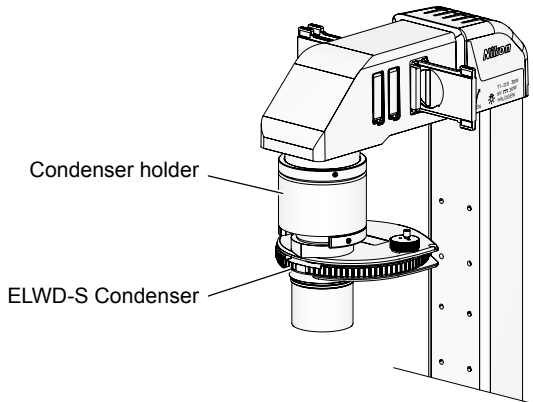


Figure 4-39 ELWD-S Condenser attachment

(2) Attaching the HMC condenser

1. Attach the 52 mm polarization filter to the extension tube provided with the HMC condenser lens.

Threads are cut on the inside of the extension tube and on the outside of the polarization filter.
2. Attach the extension tube to the dia pillar illuminator.
3. Attach the condenser holder to the extension tube.
4. Attach the turret on the system condenser to the condenser holder.
5. Screw in the HMC condenser lens into the turret.
6. Attach the HMC condenser cassette to the turret.

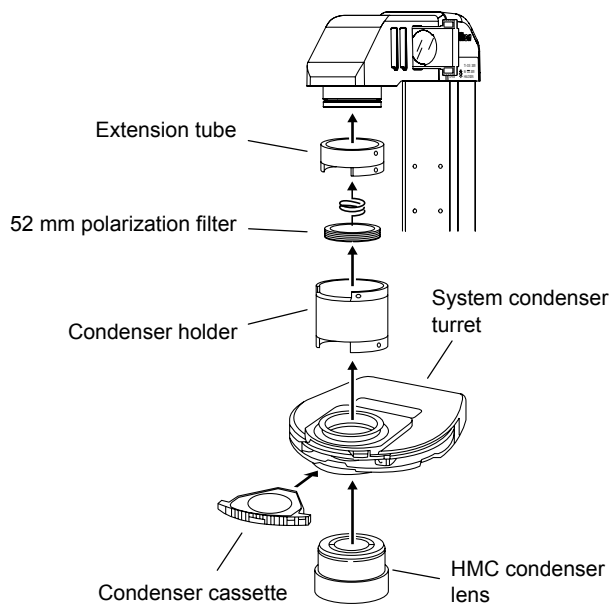


Figure 4-40 HMC Condenser attachment (system condenser)

11 Attaching the side port

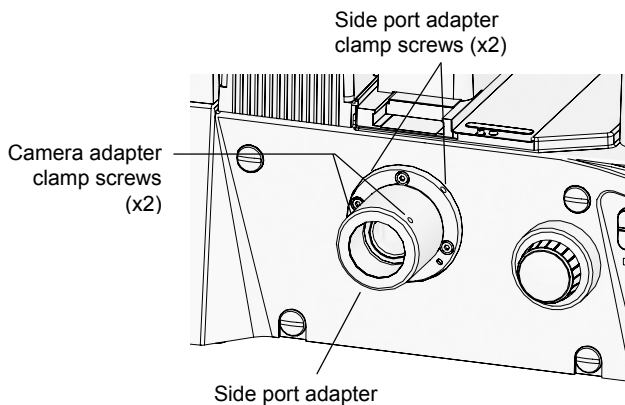


Figure 4-41 Side port adapter attachment

1. Loosen the two side port adapter clamp screws and remove the plastic cap from the side port.
2. Insert the side port adapter into the side port, and secure it by tightening the side port adapter clamp screws.
3. Attach adapters to the camera device.
4. Insert the adapters and the camera device into the side port adapter, and secure them by tightening the two camera adapter clamp screws.

- Camera devices require compatible adapters for attachment. First attach the adapters to the camera device, and then attach the camera device with the adapters into the side port adapter.
- Attach a protective cap onto the port when the port is not in use.

Example: Attaching the C mount TV camera to the direct C mount adapter

- (1) Screw the C mount TV camera securely into the direct C mount adapter.
- (2) Insert the direct C mount adapter into the side port adapter, and secure it by tightening the locking screw.

- When detaching photomicrographic equipment, hold it steady, and then loosen the locking screw.
- If the locking screw is loosened without holding the equipment, the equipment may drop. To avoid dropping photomicrographic equipment, make sure you have a firm grip before loosening the screw.

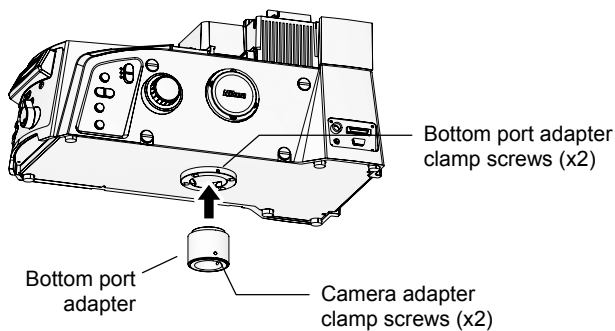
12 Attaching the bottom port (Ti-E/B only)

Figure 4-42 Bottom port adapter attachment

1. Loosen the two bottom port adapter clamp screws and remove the metal cap from the bottom port.
2. Insert the bottom port adapter into the bottom port, and secure it by tightening the two bottom port adapter clamp screws.
3. Attach adapters to the camera device.
4. Insert the adapters and the camera device into the bottom port adapter, and secure them by tightening the two camera adapter clamp screws.

- Camera devices require compatible adapters for attachment. First attach the adapters to the camera device, and then attach the camera device with the adapters into the bottom port adapter.
- Attach a protective cap onto the port when the port is not in use.

Example: Attaching the C mount TV camera to the direct C mount adapter

- (1) Screw the C mount TV camera securely into the direct C mount adapter.
- (2) Insert the direct C mount adapter into the bottom port adapter, and secure it by tightening the locking screw.

- When detaching photomicrographic equipment, hold it steady, and then loosen the locking screw.
- If the locking screw is loosened without holding the equipment, the equipment may drop. To avoid dropping photomicrographic equipment, make sure you have a firm grip before loosening the screw.

13 Connecting the power supply device

A power supply device is required to turn on the dia illumination lamp. Check that the POWER switch on the power supply device is turned off (pressed on the "O" side), and then connect the power supply as described below.

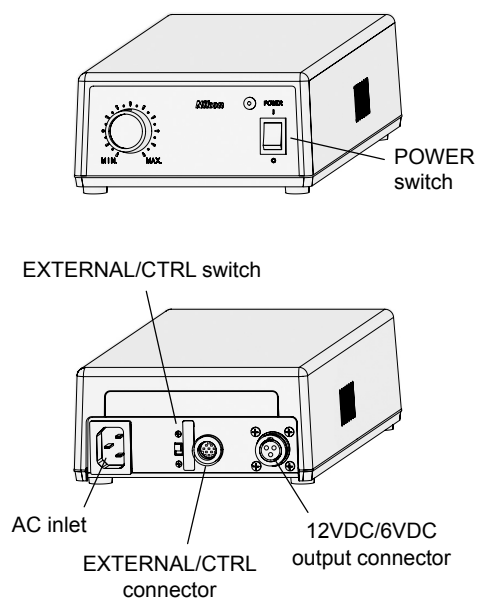


Figure 4-43 Power supply

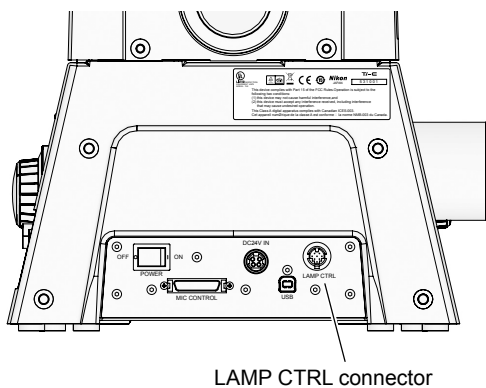


Figure 4-44 Ti-E, Ti-E/B (rear view)

(1) Lamp cable

Connect the lamp cable from the dia pillar illuminator to the DC output connector on the power supply device. A lock ring is provided on the lamp cable connector. Secure the lamp cable with the lock ring.

For Dia Pillar Illuminator 100W

Connect the lamp cable from the D-LH/LC lamphouse to the 12VDC output connector on the TI-PS100W Power Supply.

Before connecting the cable, check that the ferrite core is properly attached to the connector end of the lamphouse cable (see page 100).

For Dia Pillar Illuminator 30W

Connect the lamp cable from the dia pillar illuminator to the 6VDC output connector on the TE-PS30W/TE-PSE30 Power Supply A.

Before connecting the cable, check that the ferrite core is properly attached to the pillar end of the lamphouse cable (see page 101).

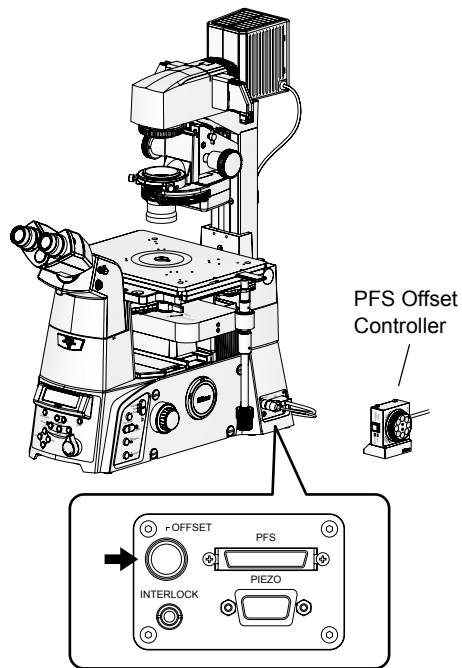
(2) Control cable

Connect one end of the control cable to the LAMP CTRL connector on the rear of the microscope, and the other end to the EXTERNAL connector on the TI-PS100W Power Supply or the CTRL connector on the TE-PS30W/TE-PSE30 Power Supply A.

(3) Power cord

Connect the plug end of the power cord to the wall outlet, and the other end to the AC inlet connector on the power supply.

To prevent electric shock, do not connect the power cord until all other assembly procedures are completed.

14 Connecting the PFS Offset Controller

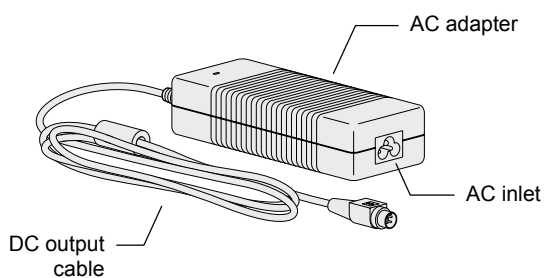
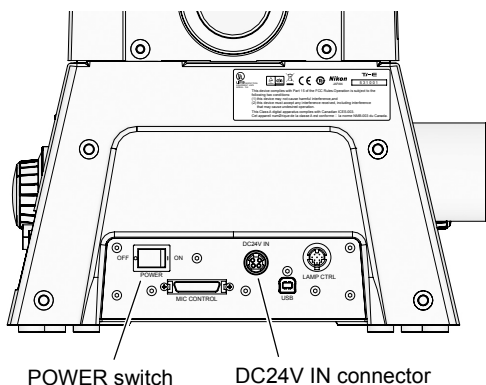
When using the PFS Motorized Nosepiece, connect the PFS Offset Controller to the Ti-E or Ti-E/B microscope body.

Connect the cable from the PFS Offset Controller to the OFFSET connector on the right side of the microscope body.

Figure 4-45 PFS Offset Controller connection

15 Connecting the AC adapter**Caution**

- Use the AC adapter included with the product.
- Use a power cord specified in Chapter 7, “Specifications”.
- To prevent electric shock, do not connect the power cord until all other assembly procedures are completed.

**Figure 4-46 AC adapter****Figure 4-47 Ti-E, Ti-E/B (rear view)**

Power to the microscope is supplied via an AC adapter.

The AC adapter can be used with 100 to 240VAC at 50/60Hz, and can be used with most wall outlets in the world.

1. Check that the **POWER** switch on the Ti-E or Ti-E/B is turned off (the **POWER** switch is set to the “OFF” side).
2. Connect the DC output cable from the AC adapter to the DC24V IN connector on the rear connector panel of the microscope.
3. Connect the AC adapter to a wall outlet with a specified power cord.

This is the end of the standard system assembly. Refer to the figure on page 117 to check the assembly result.

When using the Perfect Focus Unit, proceed to “16. Registering objectives” to register the objectives attached to the microscope.

16 Registering objectives



Caution

Notes on registering objectives

- **To register objectives, connect the microscope to a PC, and turn on their power. Check that all assembly and connection procedures are complete before proceeding.**

To use the PFS Motorized Nosepiece, you will need to register the objective information on the microscope. This section describes how to register the objective information on the Ti-E or Ti-E/B microscope body.

When using TI-HUBC/A Hub Controller A and TI-RCP Remote Control Pad, the objective information can be registered from the remote control pad. For details, refer to the instruction manual provided with the TI-RCP Remote Control Pad.

(1) Preparing the software

To register the objective information on the microscope, install the following software on a commercial PC.

- **Nikon “Ti-Control”**

The “Ti Control” software and its instruction manual can be downloaded from the following website.

<http://www.coolscope.com/eng/service/download/DLTop.aspx>

User registration is required to download the software.

For details on using the software, refer to its instruction manual.

For details on using the software and setting up the microscope, refer to the online help and instruction manual.

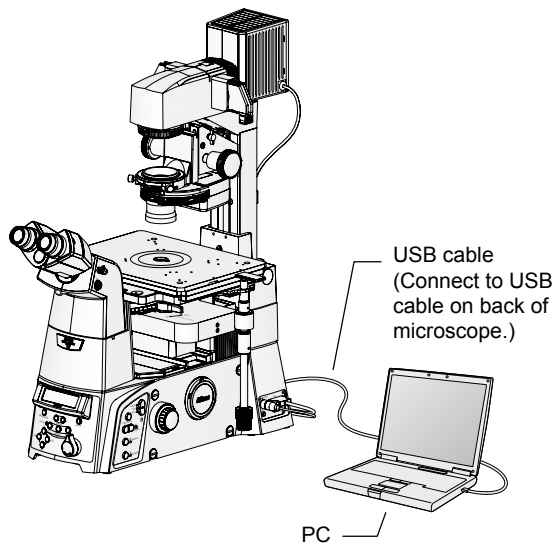
(2) Registering the objective information

Figure 4-48 Connecting microscope and PC (example)

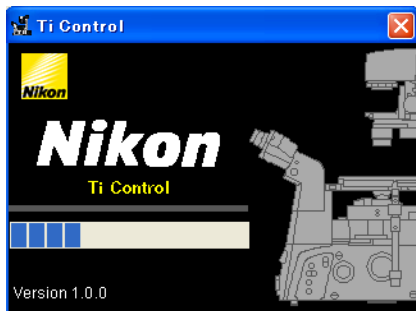


Figure 4-49 “Ti Control” startup screen

- 1. Using a standard USB cable, connect the USB connector on the microscope to the USB connector on the PC.**
- 2. Install the registration software onto the PC.**
Install “Ti Control”. For the software installation details, refer to the instruction manual of the software.
- 3. Start the installed software, and register the information for the objectives attached to the PFS Motorized Nosepiece.**
Information for PFS-compatible objectives is pre-registered on the software. For each socket on the nosepiece, specify the objective to be used.
- 4. Save the registered information.**
The settings are stored on the built-in memory of the microscope.
- 5. Exit the software, and disconnect the USB cable from the PC and the microscope.**

A list of PFS-compatible objectives (as of October 2007) are provided on page 127. To register future objectives with PFS support, contact Nikon.

System Configuration

The illustrations below show the Ti-E microscope body with the following accessories:

TI-DH Dia Pillar Illuminator 100W, TI-C Condenser Turret, D-LH/LC Precentered Lamphouse LC, 12V 100W halogen lamp, TI-PS100W Power Supply, TI-SR Rectangular Mechanical Stage, TI-T-B Eyepiece Base Unit, TI-TD Eyepiece Tube B, CFI 10x eyepieces, TI-ND6-PFS Perfect Focus Unit, objectives, etc.

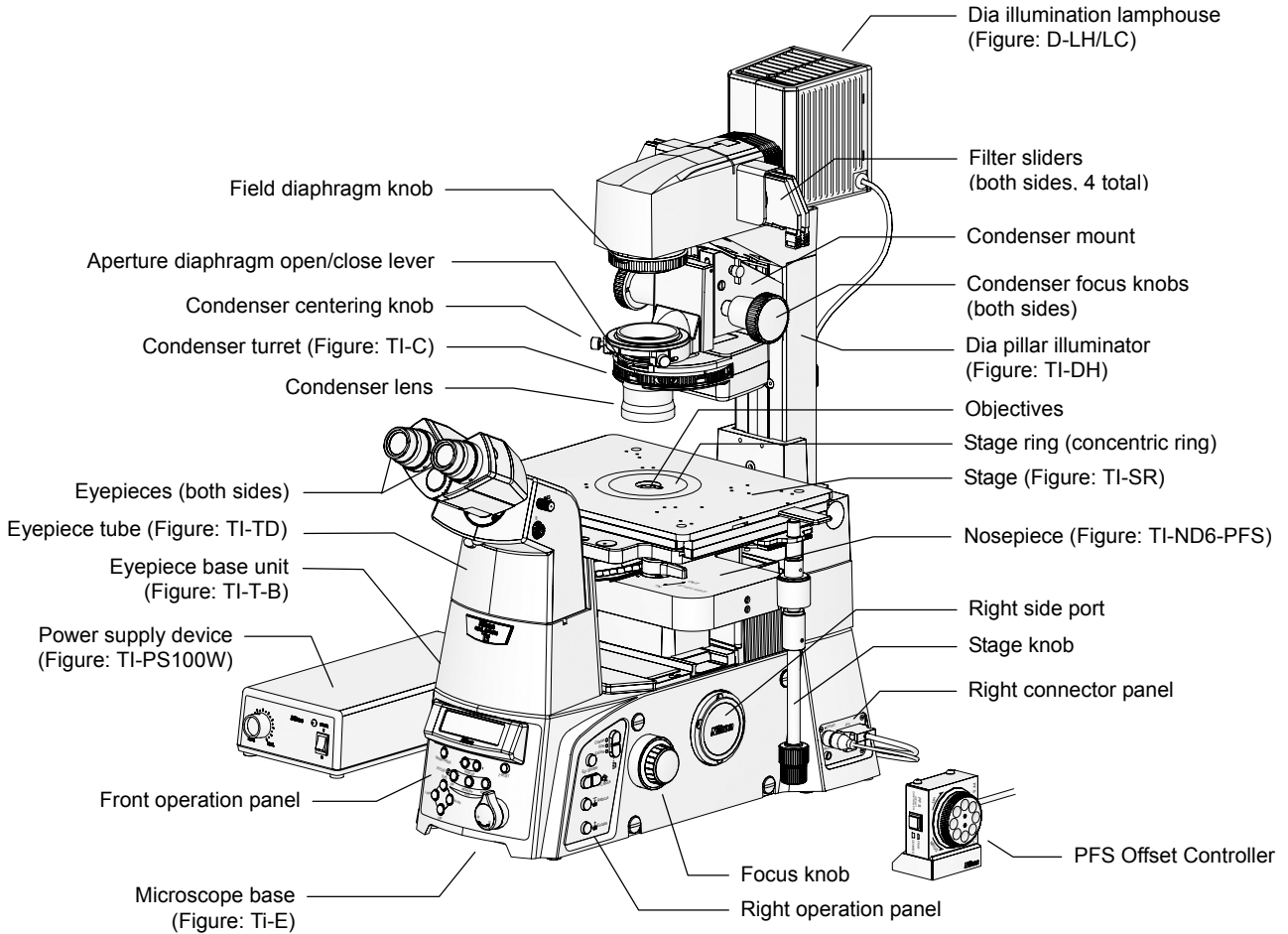


Figure 4-50 Ti-E

5

Troubleshooting

Misuse of the product may result in poor product performance, even if the product is properly functional. If you experience any of the following problems, check the following table for possible causes before requesting service.

If the problem is not listed below, or if the problem cannot be resolved by the suggested countermeasure, unplug the power cord and contact Nikon.

5.1 Image Viewing

Problem	Possible cause	Countermeasure
Vignetted field of view. No visible image. Uneven brightness in field of view. Image too dark.	Incorrectly attached part.	Attach all parts correctly.
	Movable part in inappropriate position.	The following parts must be moved to click-stop positions: optical path selector knob, nosepiece, filter sliders, condenser turret, and Bertrand lens in/out lever.
	Interference of the concentric ring on the stage with the optical path.	Move the specimen.
	Field diaphragm image not focused on focal plane of specimen.	Focus and center the condenser correctly.
	Opening of the field diaphragm too narrow.	Open the field diaphragm to be slightly larger than the field of view.
	Dirt or dust on the lens or other optical element, or on the culture vessel.	Clean the optical elements. Use a clean culture vessel.
Dirt or dust is seen in the field of view.	Dirt or dust on the lens or other optical element, or on the culture vessel.	Clean the optical elements. Use a clean culture vessel.
	Field diaphragm image not focused on focal plane of specimen.	Focus and center the condenser correctly.
Poor image quality. Poor contrast or resolution.	Dirt or dust on the lens or other optical element, or on the culture vessel.	Clean the optical elements. Use a clean culture vessel.
	Objective correction ring not matched to culture vessel's bottom plate thickness.	Use an appropriate correction ring.
	Culture vessel's bottom plate thickness is out of the objective's correction range.	Use a culture vessel with bottom plate thickness within the correction range.
	Field diaphragm image not focused on focal plane of specimen.	Focus and center the condenser correctly.
Phase contrast effect cannot be obtained in phase contrast microscopy.	Bright-field objective used.	Use a phase contrast objective.
	Condenser annular diaphragm not in the optical path.	Move an annular diaphragm with the same Ph code as the phase contrast objective into the optical path.
	Annular diaphragm not centered.	Center the annular diaphragm.
	Aperture diaphragm of system condenser not fully open.	Fully open the diaphragm.

5.1 Image Viewing

Problem	Possible cause	Countermeasure
Uneven focus.	Nosepiece attached incorrectly. Or its rotation is not stopped at a click-stop position.	Attach the nosepiece correctly and rotate it to a click-stop position.
Drifting image.	Specimen not level with stage.	Set the specimen onto the stage correctly.
	Nosepiece attached incorrectly. Or its rotation is not stopped at a click-stop position.	Attach the nosepiece correctly and rotate it to a click-stop position.
	Annular diaphragm not centered.	Center the annular diaphragm.
	Tilted dia pillar illuminator.	Raise the dia pillar illuminator upright until it reaches the limit.
Yellow-tinged image.	NCB11 filter not in optical path.	Move the ND filter into the optical path.
	Lamp voltage too low.	Adjust brightness control knob to match lamp rating.
Field of view too bright.	ND filter not in optical path.	Move the ND filter into the optical path.
	Lamp voltage too high.	Lower lamp voltage with the brightness control knob.
Insufficient brightness in field of view.	Opening of the aperture diaphragm too narrow.	Set the aperture diaphragm to 70 to 80% of the numerical aperture of the objective.
	Field diaphragm image not focused on focal plane of specimen.	Focus and center the condenser correctly.
	Optical path not set to the observation port.	Use the optical path selector switches and set the optical path to the observation port.

5.2 Operation

Problem	Possible cause	Countermeasure
Image cannot be focused even with the objective at the highest position.	Stage attached incorrectly.	Attach the stage correctly.
Image cannot be focused with 20x or 40x objective.	Culture vessel's bottom plate thickness is out of the objective's correction range.	Use a culture vessel with bottom plate thickness within the correction range.
When viewed through the binocular eyepiece, the images do not merge into a single image.	Interpupillary distance not adjusted.	Adjust the interpupillary distance.
Eyestrain develops during observations.	Diopters not adjusted.	Adjust the diopters.
	Inappropriate brightness.	Adjust brightness of lamp, or use ND filters.

5.3 Electrical System

Problem	Possible cause	Countermeasure
There is no power even though the power switch is set to ON.	The AC adapter or the power cord for the power supply is not connected at all, or is not connected securely.	Turn off the power switch, and check connection of AC adapter and power cord.
The dia illuminator lamp does not light.	Dead lamp.	Replace with a specified lamp.
Dia illuminator lamp burns out in a short time.	Unsupported lamp used.	Replace with a specified lamp.
The brightness of the lamp does not change even when the brightness control knob on the microscope is rotated.	Control cable not connected correctly.	Check connection of cable.
	EXTERNAL (or CTRL) switch on the power supply is turned off.	Turn the switch on.
The lamp does not turn on/off even when the dia illumination ON/OFF switch is operated.	Dead lamp.	Replace with a specified lamp.
	Control cable not connected correctly.	Check connection of cable.
The brightness of the lamp does not change even when the brightness control knob on the power supply device is rotated.	EXTERNAL (or CTRL) switch on the power supply is turned on.	Turn the switch off.

5.4 Perfect Focus System

Problem	Possible cause	Countermeasure
PFS information not displayed on status display panel.	PFS information is not selected as a display item.	Press the DISPLAY switch to display PFS information.
	PFS Motorized Nosepiece not connected.	Attach and connect the PFS Motorized Nosepiece correctly.
FOCUS indicator lights up while PFS-ON switch is OFF.	The system is detecting the boundary surface. (This is normal behavior.)	The system continues to detect the boundary surface even when PFS is OFF. The FOCUS indicator will be lit when the boundary surface is detected. The indicator can be used to assist in focusing.
	Registered objective information incorrect. (Registered information does not match the objective in use, or information for a PFS objective is registered but no objective is attached.)	Register correct objective information. If no objective is attached, delete the objective information.
Focus position cannot be moved with the offset dial.	Offset already at limit of adjustable range.	Rotate dial in the opposite direction. The offset function must be used within the adjustable range.
	PFS Offset Controller attached incorrectly.	Turn off the power. Disconnect and reconnect the PFS Offset Controller.
Offset cannot be registered by pressing the MEMORY switch. (No beep)	MEMORY switch pressed during offset recall operation.	Retry after offset recall operation is complete.
	Objective in the optical path does not support PFS. (Panel display: ER1)	Register the objectives correctly, and move an appropriate objective into the optical path.
Offset cannot be restored by pressing the RECALL switch. (No beep)	Objective in the optical path does not support PFS. (Panel display: ER1)	Register the objectives correctly, and move an appropriate objective into the optical path.
PFS does not operate when the PFS-ON switch is pressed. (Six short beeps)	Objective in the optical path does not support PFS. (Panel display: ER1)	Register the objectives correctly, and move an appropriate objective into the optical path.
	Dichroic mirror in the PFS unit is not in the optical path. (Panel display: Out)	Move dichroic mirror into the optical path.
“DIS” appears on the status display panel.	No specimen on stage.	Set a specimen and focus on it manually.
	Objective too far from boundary surface of specimen.	Rotate focus knobs to move objective closer to the boundary surface.
	Shape or material of specimen not suitable for PFS.	Use a specimen suited for PFS. PFS will not function if the cover glass is too thick or if the refraction index of the solution is too high (n is close to 1.5). See “Supported Specimens” on page 82.

5.4 Perfect Focus System

Problem	Possible cause	Countermeasure
Focusing operation is terminated and the buzzer sounds, approx. 5 seconds after pressing the PFS-ON switch.	No specimen on stage.	Set a specimen and focus on it manually.
	Objective too far from boundary surface of specimen.	Rotate focus knobs to move objective closer to the boundary surface.
	Shape or material of specimen not suitable for PFS.	Use a specimen suited for PFS. PFS will not function if the cover glass is too thick or if the refraction index of the solution is too high (n is close to 1.5). See "Supported Specimens" on page 83.
A long beep sounds during the perfect focus operation and the perfect focus function ends.	Boundary surface not detected within time limit. (Panel display: ER2)	When using a dry objective, PFS is turned off for safety if no boundary surface is detected within 5 seconds.
	PFS dichroic mirror not in the optical path. (Panel display: ER3)	PFS is turned off for safety. Move dichroic mirror into the optical path and turn on PFS again.
	Nosepiece is placed out of a click-stop position. (Panel display: ER4)	PFS is turned off for safety. Rotate nosepiece to a click-stop position and turn on PFS again.
	Limit reached for vertical stage movement. (Panel display: ER5)	PFS is turned off for safety.
	Reflectance of specimen too high. (Panel display: ER6 or ER7)	Check that a glass-bottomed dish (No.1S) is used for the specimen.
	PFS internal error. (Panel display: ER8 or ER9)	Contact Nikon.

6

Daily Maintenance

6.1 Cleaning Optical Components

Do not allow dust, fingerprints, or any other dirt to get on the optical components (i.e. lenses and filters). Dirt on optical components will degrade the image quality. If an optical component becomes dirty, clean them as described below.

- Remove any dust by brushing off with a soft brush or by wiping gently with gauze.
- If and only if there are fingerprints or grease on the optical component, wipe gently with a piece of soft, clean lens tissue, cotton cloth, or gauze dampened with a small amount of absolute alcohol (ethyl or methyl).
- When removing immersion oil from an objective, use only petroleum benzine. After wiping with petroleum benzine, wipe with absolute alcohol (ethyl or methyl) for a better finish. If petroleum benzine is unavailable, use methyl alcohol. However, as methyl alcohol does not clean as well as petroleum benzine, it will be necessary to wipe a few more times (usually three to four wipes).
- Never use petroleum benzine to clean the entrance lens or the prism surface of the eyepiece tube.
- Absolute alcohol is highly flammable. Handle with care. Do not use near an open flame, or operate a power switch in the vicinity.
- When using absolute alcohol, follow the instructions provided by the manufacturer.

6.2 Cleaning the Microscope Body

- Use silicon cloth to clean the microscope body.
- For persistent dirt, dampen a piece of gauze with neutral detergent and wipe gently.
- Do not use organic solvents. They may cause discoloration of plastic parts.

6.3 Disinfecting the Microscope

- Use a 70% medical alcohol for disinfection.
- If a specimen is spilt onto the microscope, check if the specimen is hazardous. If the specimen is hazardous, follow the standard procedures for your facility.
- Do not use organic solvents. They may cause discoloration of plastic parts.

6.4 Storage

- Store the product in a dry location where mold is unlikely to grow.
- Store the objectives and eyepieces in a desiccator or equivalent, along with some desiccant.
- Put a dust-proof cover over the product to protect it from dust.
- Before putting on the dust-proof cover, turn off the power switch on the equipment (press the "OFF" side or the "O" side) and wait until the lamp has cooled sufficiently.

6.5 Periodic Inspections (Paid Service)

Periodic inspections (expenses charged) are recommended to maintain the performance of the product. For details, contact Nikon.

7

Specifications

7.1

Microscope (Ti-E or Ti-E/B) with TI-DH Dia Pillar Illuminator 100W

System configuration	Microscope, TI-DH Dia Pillar Illuminator 100W, and TI-PS100W Power Supply	
Dimensions	260 (W) x 559 (D) x 729 (H) mm	
Mass	26.5 kg	
Optical system	Objectives:	CFI60
	Eyepieces:	Field number 22
	Nosepiece:	Six sockets
Mechanical system	Focusing mechanism:	Stroke: 10 mm
	Focus knobs:	Coarse focus: 300 μ m per rotation (reference value)* Fine focus: 50 μ m per rotation Extra fine focus: 6.25 μ m per rotation
		* When set to COARSE mode, the distance traveled by rotating a focus knob will vary depending on how fast the knob is rotated.
D-LH/LC Precentered Lamphouse LC	Input ratings:	12 VDC, 100 W
	Lamp ratings:	12 V 100 W halogen lamp
	Specified lamp model:	Halogen lamp (OSRAM HLX 64623 or PHILIPS 7724I)
	Average lamp life:	2000 hours
TI-PS100W Power Supply	Input ratings:	100 to 240 VAC (\pm 10%), 1.8 A, 50/60 Hz
	Built-in fuse ratings:	250 V T4A
	Output ratings:	12 VDC, 100 W
	Maximum output current:	8.4 A
	Electric shock protection class:	Class I
	Remarks:	UL listed product, GS approved
Operating conditions	Temperature:	0 to 40°C
	Relative humidity:	85% RH max. with no condensation
	Altitude:	2000 m max.
	Pollution degree:	Degree 2
	Installation category:	Category II
	Indoor use only	
Transport and storage conditions	Temperature:	-20 to +60°C
	Relative humidity:	90% RH max. with no condensation

7.2**Microscope (Ti-E or Ti-E/B) with TI-DS Dia Pillar Illuminator 30W**

System configuration	For countries with power supply of 100 to 120 VAC: Microscope, TI-DS Dia Pillar Illuminator 30W, and TE-PS30W Power Supply A For countries with power supply of 220 to 240 VAC: Microscope, TI-DS Dia Pillar Illuminator 30W, and TE-PSE30 Power Supply A
Dimensions	260 (W) x 497 (D) x 619 (H) mm
Mass	22.5 kg
Optical system	Objectives: CFI60 Eyepieces: Field number 22 Nosepiece: Six sockets
Mechanical system	Focusing mechanism: Stroke: 10 mm Focus knobs: Coarse focus: 300 µm per rotation (reference value)* Fine focus: 50 µm per rotation Extra fine focus: 6.25 µm per rotation * When set to COARSE mode, the distance traveled by rotating a focus knob will vary depending on how fast the knob is rotated.
TI-DS Dia Pillar Illuminator 30W	Input ratings: 6 VDC, 30 W Lamp ratings: 6 V 30 W halogen lamp Specified lamp model: Halogen lamp (PHILIPS 5761) Average lamp life: 100 hours
TE-PS30 Power Supply A TE-PSE30 Power Supply A	Input ratings: TE-PS30W: 100 to 120 VAC (±10%), 50/60 Hz, 0.7 A TE-PSE30: 230 VAC (±10%), 50/60 Hz, 0.3 A Built-in fuse ratings: 250 V F2AH Output ratings: 6 VDC, 30 W Maximum output current: 5.0 A Electric shock protection class: Class I Remarks: TE-PS30W: UL listed product TE-PSE30: GS approved
Operating conditions	Temperature: 0 to 40°C Relative humidity: 85% RH max. with no condensation Altitude: 2000 m max. Pollution degree: Degree 2 Installation category: Category II Indoor use only
Transport and storage conditions	Temperature: -20 to +60°C Relative humidity: 90% RH max. with no condensation

7.3

PFS Motorized Nosepiece and PFS Offset Controller

Model name	TI-ND6-PFS PFS Motorized Nosepiece
Detectable object	<p>Supported specimen: Cells in culture solution near the cover glass of a glass-bottomed dish</p> <p>Cover glass: Thickness: 150 to 180 μm (No.1S) Refractive index: 1.5</p> <p>Culture solution Depth: 3 mm or greater Refractive index: Approx. 1.33</p> <p>Detectable boundary surface: Water/oil immersion objectives: Boundary surface between glass and specimen (culture solution) Dry objectives: Boundary surface between glass and air</p> <p>Recommended oil (for oil immersion): Nikon Immersion Oil B (1250CST)</p>
Detection method	<p>Detection method: Active type, infrared LED light projection method</p> <p>Detector: Inline CMOS sensor</p> <p>Detector light source: Infrared LED (wavelength: 880 nm, radiation power: 0.1mW or less)</p>
Offset control	<p>Offset method Optical offset method Controllable with the offset dial on the PFS offset controller</p> <p>Offset Dry objectives: +100 to -10 μm Water immersion objectives: +20 to -2 μm Oil immersion objectives: 100x: +5 to -0.5 μm 60x: +10 to -0.5 μm</p> <p>Note 1: Some objectives offer a wider offset range. Note 2: The following objectives feature special offset ranges.</p> <p>S Fluor DL 40xC: +30 to -10 μm Plan Apo 40x: +30 to -10 μm Plan Apo DM 40x: +30 to -10 μm Plan Apo TIRF 60xH: +5 to -0.5 μm Apo TIRF 60xH: +5 to -0.5 μm</p>
Focusing performance	<p>Focusing time 700 msec or less at a position near the focal point (at the boundary surface)</p> <p>Focusing accuracy 1/3 or less of the focal depth of the objective</p>
Applicable microscopy	Bright-field, phase contrast, DIC, fluorescence, and TIRF
Built-in optical elements	<p>IR filter: Passes light of 340 to 750 nm.</p> <p>DM filter: Passes light of 340 to 770 nm and 925 to 1100 nm</p>
Memory function	<p>Offset registration/recall (for each objective, up to 6 total)</p> <p>Nosepiece vertical position registration/recall (for each objective, up to 6 total)</p>
Dimensions and mass	<p>PFS nosepiece: Dimensions: 87 (H) x 232 (W) x 187 (D) mm (excluding protrusions) Mass: 2 kg</p> <p>PFS offset controller: Dimensions: 99 (H) x 75 (W) x 72 (D) mm (excluding protrusions) Mass: 0.6 kg</p>
Operating conditions	<p>Temperature: +20 to +38°C</p> <p>Relative humidity: 60% RH max. with no condensation Controller only: 80% RH max. with no condensation</p> <p>Altitude: 2000 m max.</p> <p>Pollution degree: Degree 2</p> <p>Installation category: Category II</p> <p>Indoor use only</p>
Storage conditions	<p>Temperature: -20 to +60°C</p> <p>Relative humidity: 90% RH max. with no condensation</p>

7.3 PFS Motorized Nosepiece and PFS Offset Controller

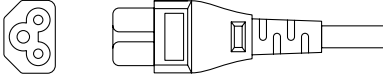
	Device	NA	WD (mm)	Type
Supported objective	Apo TIRF 60xH	1.49	0.12	Oil
	Apo TIRF 100xH	1.49	0.12	Oil
	Plan Apo 4x	0.2	15.7	Dry
	Plan Apo 10x	0.45	4	Dry
	Plan Apo 20x	0.75	1	Dry
	Plan Apo 40x	0.95	0.14	Dry
	Plan Apo DM 40x	0.95	0.14	Dry
	Plan Apo 60xHA	1.4	0.21	Oil
	Plan Apo 60xWI	1.2	0.22	WI
	Plan Apo DM 60xHA	1.4	0.21	Oil
	Plan Apo DM 60xH	1.4	0.21	Oil
	Plan Apo 100xH	1.4	0.13	Oil
	Plan Apo DM 100xH	1.4	0.13	Oil
	Plan Apo TIRF 60xH	1.45	0.13	Oil
	Plan Apo TIRF 100xH	1.45	0.13	Oil
	Plan Apo VC 60xWI	1.2	0.27	WI
	Plan Apo VC 60xH	1.4	0.13	Oil
	Plan Apo VC 100xH	1.4	0.13	Oil
	Plan Fluor 10x	0.3	16	Dry
	Plan Fluor DLL 10x	0.3	16	Dry
	Plan Fluor ELWD 20xC	0.45	7.4	Dry
	Plan Fluor ELWD ADL 20xC	0.45	7.4	Dry
	Plan Fluor ELWD DM 20xC	0.45	7.4	Dry
	Plan Fluor 40x	0.75	0.72	Dry
	Plan Fluor 40xH	1.3	0.2	Oil
	Plan Fluor DLL 40x	0.75	0.72	Dry
	Plan Fluor ELWD 40xC	0.6	3.7-2.7	Dry
	Plan Fluor ELWD ADL 40xC	0.6	3.7-2.7	Dry
	Plan Fluor ELWD DM 40xC	0.6	3.7-2.7	Dry
	Plan Fluor 100xH	1.3	0.2	Oil
	Plan Fluor ADH 100xH	1.3	0.19	Oil
	Plan Fluor DLL 100xH	1.3	0.2	Oil
	S Fluor 4x	0.2	15.5	Dry
	S Fluor 10x	0.5	1.2	Dry
	S Fluor 20x	0.75	1	Dry
	S Fluor DL 20x	0.75	1	Dry
	S Fluor 40xH	1.3	0.22	Oil
	S Fluor DL 40x	0.9	0.3	Dry
	S Plan Fluor ELWD 20xC	0.45	8.2-6.9	Dry
	S Plan Fluor ELWD ADM 20xC	0.45	8.2-6.9	Dry
S Plan Fluor ELWD 40xC	0.6	3.6-2.8	Dry	
S Plan Fluor ELWD ADM 40xC	0.6	3.6-2.8	Dry	

7.4 AC Adapter


Model name	FSP120-ACB
Manufacturer	FSP Group Inc.
Input voltage ratings	100 to 240 VAC, 2 A, 50-60 Hz
Voltage fluctuation	±10%
Output voltage ratings	24 VDC
Output current ratings	5 A
Remarks	UL listed, GS approved, CE compliant, and PSE approved product

7.5 Power Cord


7.5.1 Power Cord for the AC Adapter

AC inlet and plug appearance	
For countries where the power supply is 100 to 120 VAC but not Japan	UL listed detachable power cord set, 3 conductor grounding (3 conductor grounding Type SVT, No.18 AWG, 1.8 m long maximum, rated at 125V AC minimum)
For countries where the power supply is 220 to 240 VAC	Detachable power cord set approved according to EU/EN standard, 3 conductor grounding (3 conductor grounding Type H05VV-F, 2.5 m long maximum, rated at 250V AC minimum)
For Japan	PSE approved detachable power cord set, 3 conductor grounding (3 conductor grounding Type VCTF 3x0.75mm ² , 1.8 m long maximum, rated at 125V AC minimum)

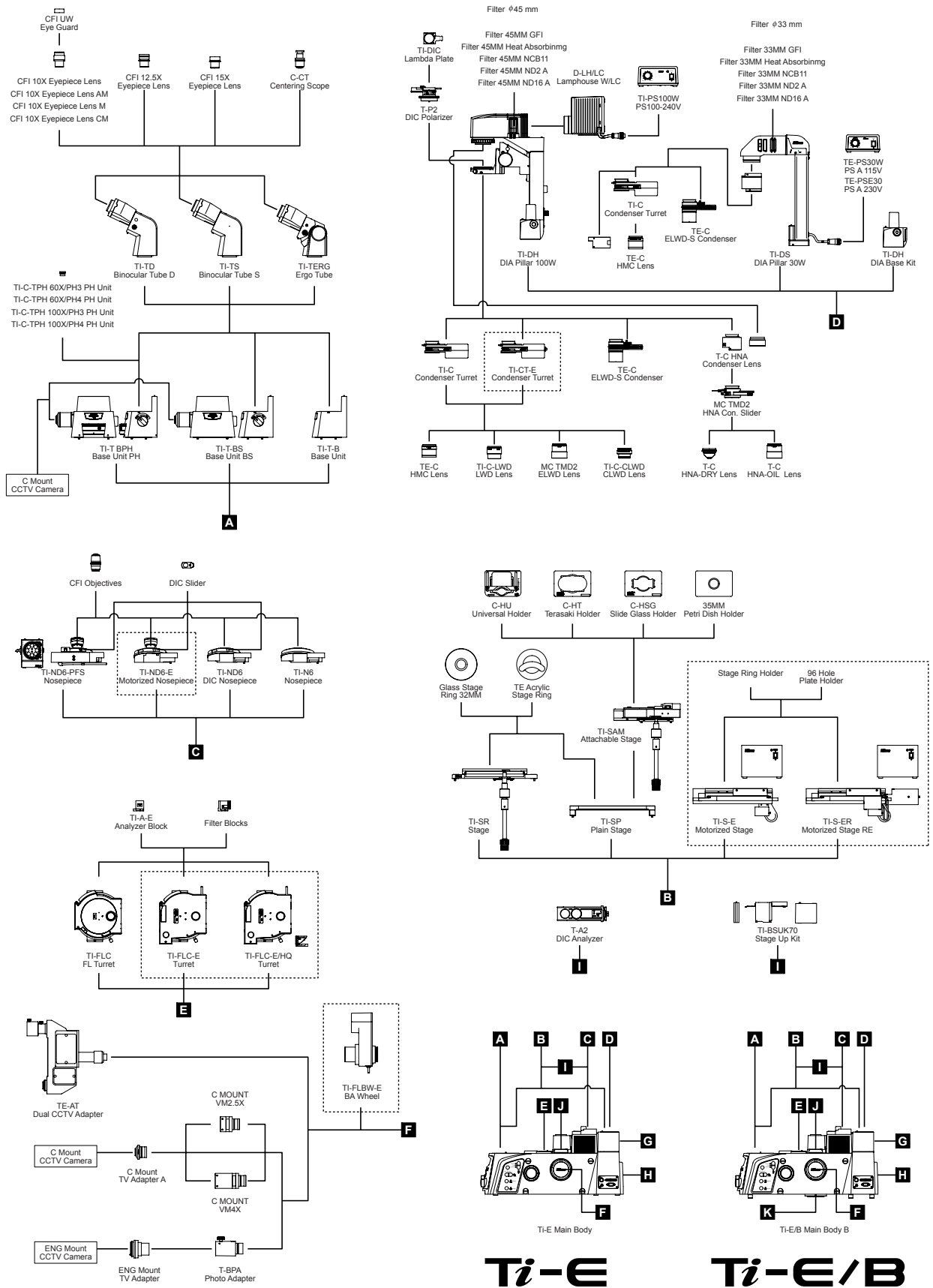
7.5.2 Power Cord for the Power Supply

AC inlet and plug appearance	
For countries where the power supply is 100 to 120 VAC but not Japan	UL listed detachable power cord set, 3 conductor grounding (3 conductor grounding Type SVT, No.18 AWG, 3 m long maximum, rated at 125V AC minimum)
For countries where the power supply is 220 to 240 VAC	Detachable power cord set approved according to EU/EN standard, 3 conductor grounding (3 conductor grounding Type H05VV-F, 3 m long maximum, rated at 250V AC minimum)
For Japan	PSE approved detachable power cord set, 3 conductor grounding (3 conductor grounding Type VCTF 3x0.75mm ² , 3 m long maximum, rated at 125V AC minimum)

7.6 Safety Standards Compliance

<p>Configuration of Ti-E microscope, with TI-PS100W Power Supply or TE-PS30W Power Supply A</p>	<ul style="list-style-type: none"> • UL listed product. • This product meets FCC Part 15B Class A requirements: This equipment has been tested and found to comply with the limits for a Class A digital device, pursuant to Part 15 of the FCC Rules. These limits are designed to provide reasonable protection against harmful interference when the equipment is operated in a commercial environment. This equipment generates, uses, and can radiate radio frequency energy and, if not installed and used in accordance with the instruction manual, may cause harmful interference to radio communications. Operation of this equipment in a residential area is likely to cause harmful interference in which case the user will be required to correct the interference at his own expense. • This product complies with Canadian EMI. (ICES-003 Class A) This Class A digital apparatus complies with Canadian ICES-003. Cet appareil numérique de classe A est conforme à la norme NMB-003 du Canada.
<p>Configuration of Ti-E microscope, with TI-PS100W Power Supply or TE-PSE30 Power Supply A</p>	<ul style="list-style-type: none"> • CE marking <ul style="list-style-type: none"> • This product meets EU IVD Directive requirements. (GM-approved: in vitro diagnostic medical device) • This product meets EU Low Voltage Directive requirements. • This product meets EU EMC Directive requirements. (EN61326) • This product complies with Australian EMC. (AS/NZS C1SPR11) <div style="text-align: right;">  </div>

System Diagram



System Diagram

